

# DATA SHEET

## **SAA7124; SAA7125** Digital Video Encoder (ECO-DENC)

Preliminary specification  
File under Integrated Circuits, IC22

1996 Nov 07

**Digital Video Encoder (ECO-DENC)****SAA7124; SAA7125****FEATURES**

- Monolithic CMOS 5 V device
- Digital PAL/NTSC encoder
- System pixel frequency 13.5 MHz
- Accepts MPEG decoded data on 8-bit wide input port. Input data format Cb, Y, Cr etc. "(CCIR 656)"
- Four DACs for CVBS (10-bit resolution), RGB (9-bit resolution) operating at 27 MHz; RGB sync on CVBS
- Optionally 2 times CVBS and Y, C (all 10-bit resolution) available simultaneously
- Closed captioning encoding
- On-chip YUV to RGB dematrix optionally to be by-passed for Cr, Y, Cb output on RGB DACs
- Fast I<sup>2</sup>C-bus control port (400 kHz)
- Encoder can be master or slave
- Programmable horizontal and vertical input synchronization phase, via input pins or auxiliary codes at MP data port
- Programmable horizontal sync output phase
- Internal 100/75 Colour Bar Generator (CBG)
- Macrovision Pay-per-View copy protection system as option, also partly used for RGB output.

This applies to SAA7124 only. The device is protected by USA patent numbers 4631603, 4577216 and 4819098 and other intellectual property rights. Use of the Macrovision anti-copy process in the device is licensed for non-commercial home use only.

Reverse engineering or disassembly is prohibited. Please contact your nearest Philips Semiconductor sales office for more information

- Controlled rise and fall times of output syncs and blanking
- Down-mode of DACs
- LQFP64 (V1 devices only), QFP80 or PLCC84 package.

**GENERAL DESCRIPTION**

The SAA7124; SAA7125 encodes digital YUV video data to an NTSC or PAL CVBS plus RGB or alternatively to S-Video and CVBS output.

Optionally, the YUV to RGB dematrix can be by-passed providing the digital-to-analog converted Cb, Y, Cr signals instead of RGB.

The circuit accepts CCIR compatible YUV data with 720 active pixels per line in 4 : 2 : 2 multiplexed formats, for example MPEG decoded data.

It includes a sync/clock generator and on-chip Digital-to-Analog Converters (DACs).

**ORDERING INFORMATION**

TYPE NUMBER	PACKAGE <sup>(1)</sup>		
	NAME	DESCRIPTION	VERSION
SAA7124WP; SAA7125WP	PLCC84	plastic leaded chip carrier; 84 leads	SOT189-2
SAA7124HZ; SAA7125HZ	LQFP64	plastic low profile quad flat package; 64 leads; body 10 × 10 × 1.4 mm	SOT314-2
SAA7124H; SAA7125H	QFP80	plastic quad flat package; 80 leads (lead length 2.35 mm); body 14 × 20 × 2.8 mm	SOT318-3

**Note**

1. LQFP64 package for V1 devices only.

## Digital Video Encoder (ECO-DENC)

## SAA7124; SAA7125

## QUICK REFERENCE DATA

SYMBOL	PARAMETER	MIN.	TYP.	MAX.	UNIT
V <sub>DDA</sub>	analog supply voltage	4.75	5.0	5.25	V
V <sub>DDD</sub>	digital supply voltage	4.75	5.0	5.25	V
I <sub>DDA</sub>	analog supply current	–	tbf	60	mA
I <sub>DDD</sub>	digital supply current	–	tbf	100	mA
V <sub>i</sub>	input signal voltage levels	TTL compatible			
V <sub>o(p-p)</sub>	analog output signal voltages Y, C, CVBS and RGB without load (peak-to-peak value)	–	2.0	–	V
R <sub>L</sub>	load resistance	80	–	–	Ω
ILE	LF integral linearity error	–	–	±4	LSB
DLE	LF differential linearity error	–	–	±1	LSB
T <sub>amb</sub>	operating ambient temperature	0	–	+70	°C

# Digital Video Encoder (ECO-DENC)

# SAA7124; SAA7125

## BLOCK DIAGRAM

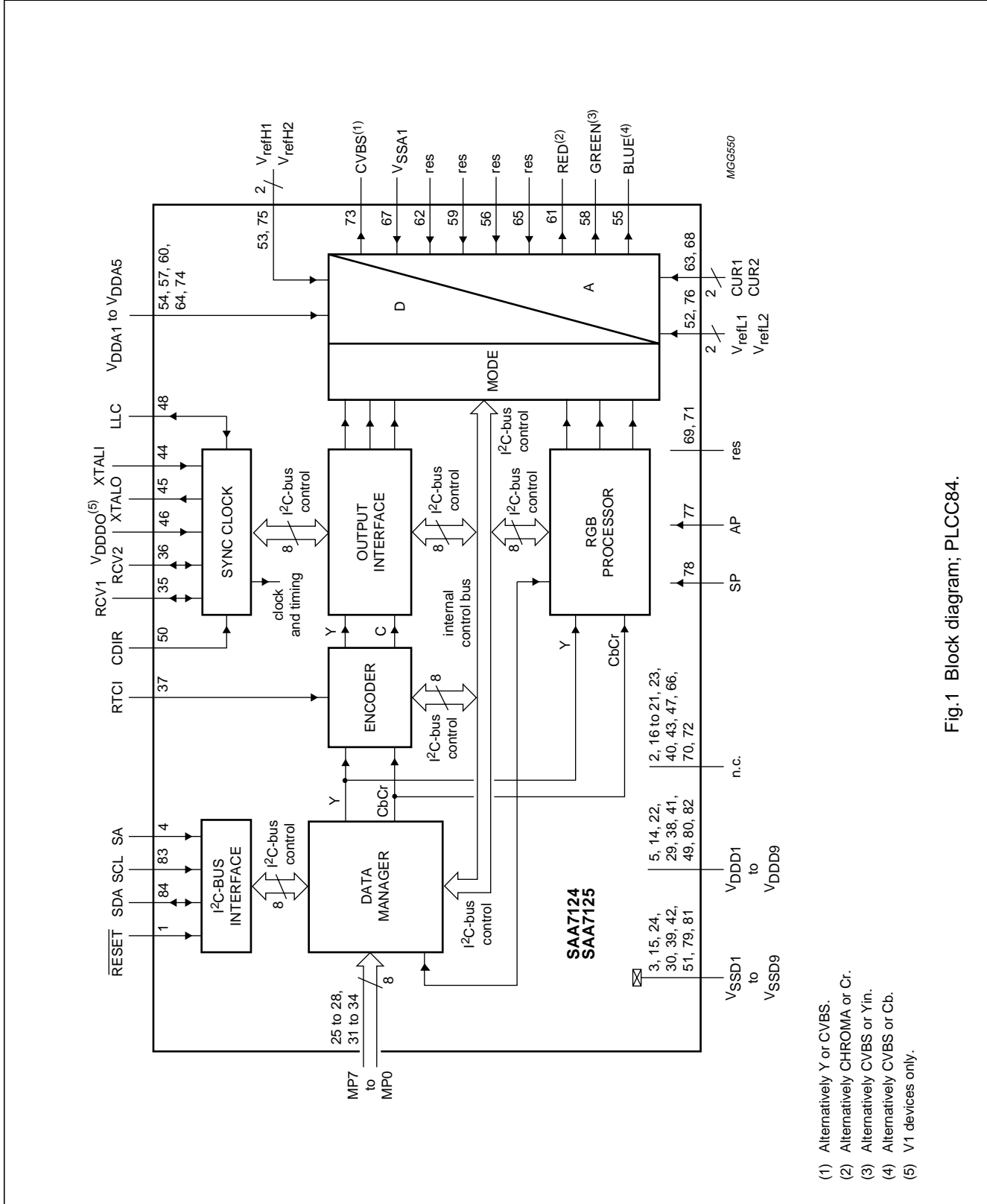

Fig.1 Block diagram; PLCC84.

- (1) Alternatively Y or CVBS.
- (2) Alternatively CHROMA or Cr.
- (3) Alternatively CVBS or Yin.
- (4) Alternatively CVBS or Cb.
- (5) V1 devices only.

Digital Video Encoder (ECO-DENC)

SAA7124; SAA7125

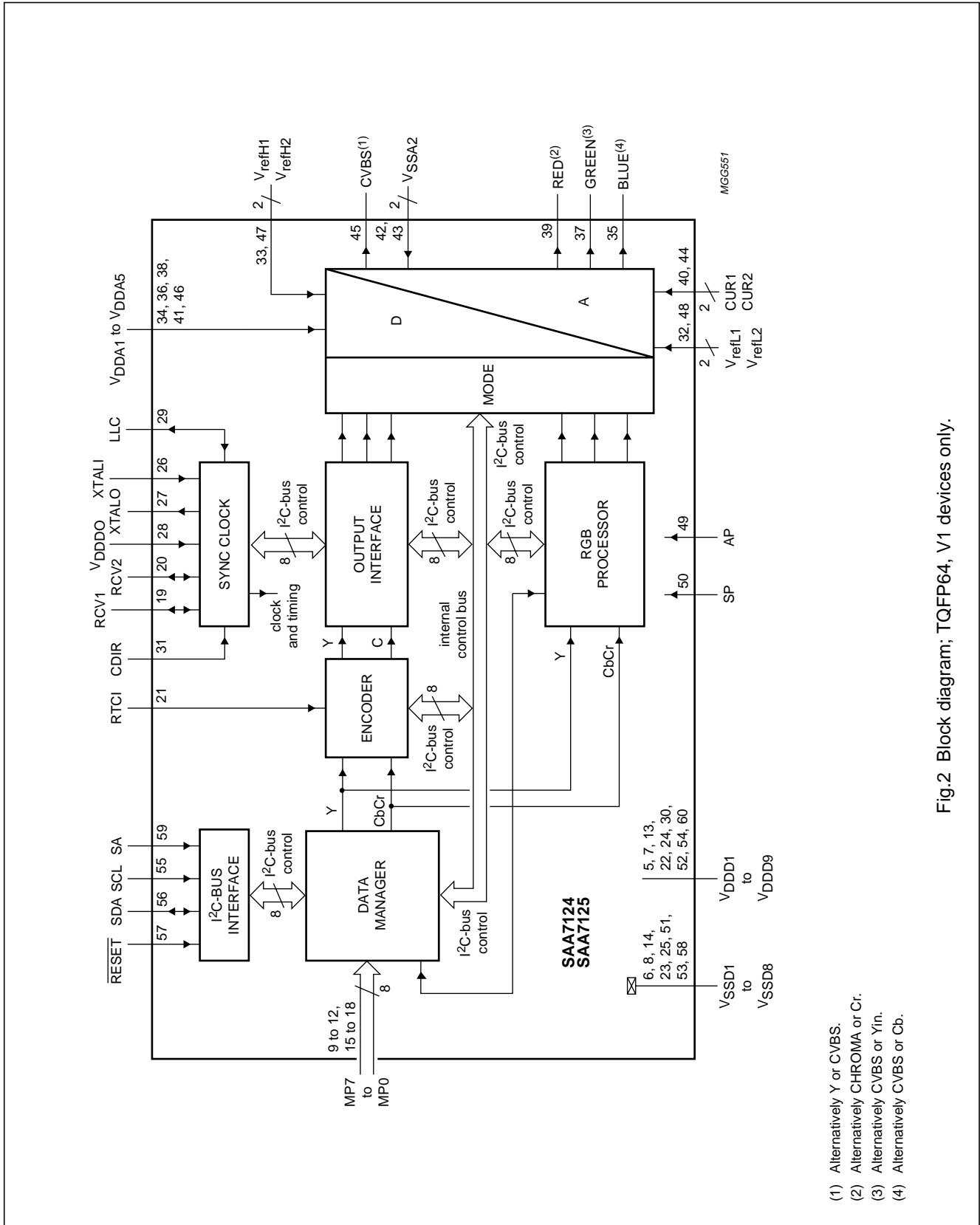

Fig.2 Block diagram; TQFP64, V1 devices only.

Digital Video Encoder (ECO-DENC)

SAA7124; SAA7125

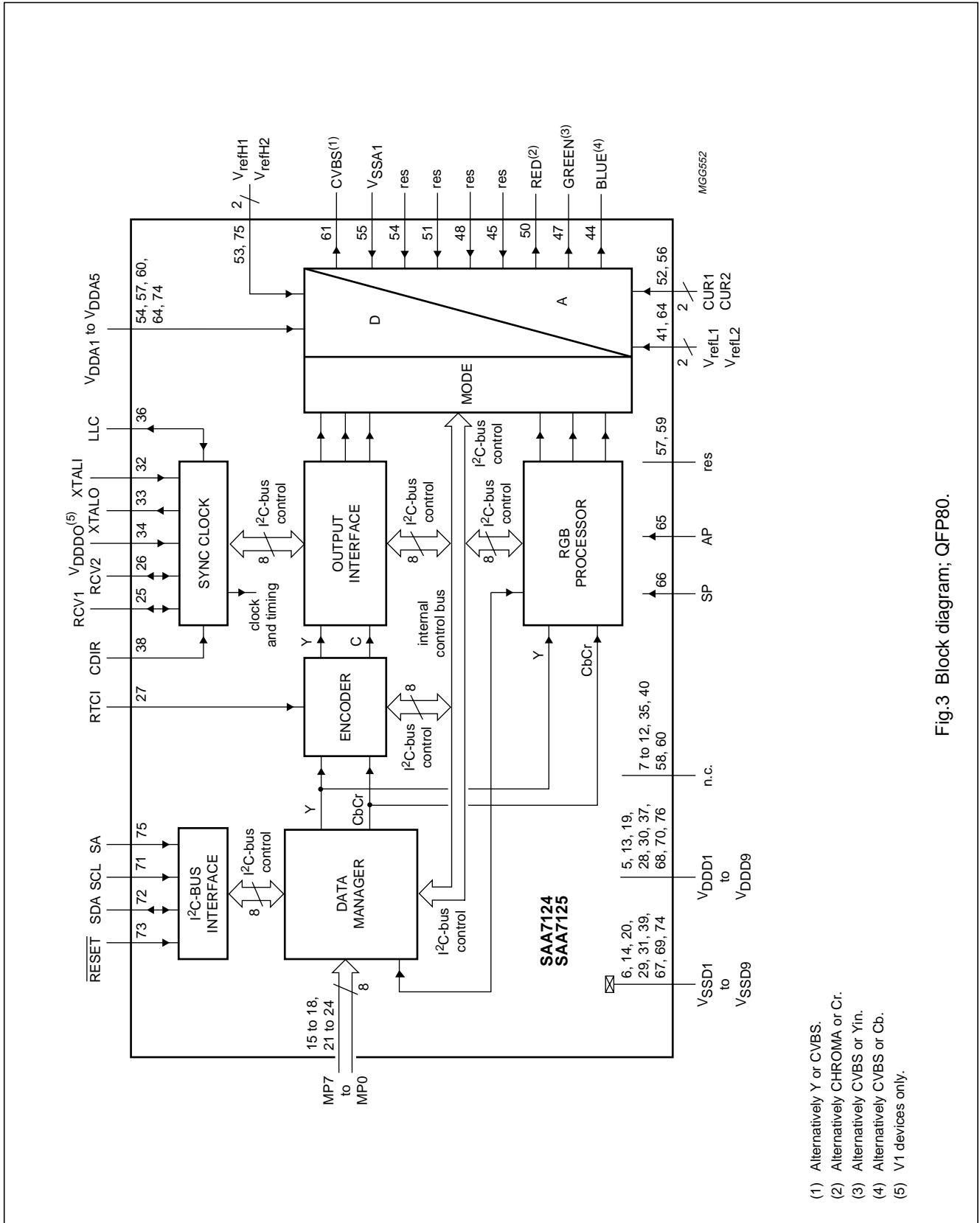

Fig.3 Block diagram; QFP80.

- (1) Alternatively Y or CVBS.
- (2) Alternatively CHROMA or Cr.
- (3) Alternatively CVBS or Yin.
- (4) Alternatively CVBS or Cb.
- (5) V1 devices only.

## Digital Video Encoder (ECO-DENC)

## SAA7124; SAA7125

## PINNING

SYMBOL	TYPE	PIN			DESCRIPTION
		PLCC84	LQFP64	QFP80	
RESET	I	1	57	73	Reset input, active LOW. After reset is applied, all digital I/Os are in input mode. The I <sup>2</sup> C-bus receiver waits for the START condition.
n.c.	–	2	–	–	not connected
V <sub>SSD1</sub>	I	3	6	6	digital ground 1
SA	I	4	59	75	The I <sup>2</sup> C-bus slave address select input pin. LOW: slave address = 88H, HIGH = 8CH.
V <sub>DDD1</sub>	I	5	5	5	digital supply voltage 1
TP1	O	6	61	77	Test pin outputs. Leave open for normal operation.
TP2	O	7	62	78	
TP3	O	8	63	79	
TP4	O	9	64	80	
TP5	O	10	1	1	
TP6	O	11	2	2	
TP7	O	12	3	3	
TP8	O	13	4	4	
V <sub>DDD2</sub>	I	14	7	13	digital supply voltage 2
V <sub>SSD2</sub>	I	15	8	14	digital ground 2
n.c.	–	16	–	7	not connected
n.c.	–	17	–	8	
n.c.	–	18	–	9	
n.c.	–	19	–	10	
n.c.	–	20	–	11	
n.c.	–	21	–	12	
V <sub>DDD3</sub>	I	22	13	19	digital supply voltage 3
n.c.	–	23	–	–	not connected
V <sub>SSD3</sub>	I	24	14	20	digital ground 3
MP7	I	25	9	15	Upper 4 bits of MPEG port. It is an input for "CCIR 656" style multiplexed Cb, Y, Cr data.
MP6	I	26	10	16	
MP5	I	27	11	17	
MP4	I	28	12	18	
V <sub>DDD4</sub>	I	29	22	28	digital supply voltage 4
V <sub>SSD4</sub>	I	30	23	29	digital ground 4
MP3	I	31	15	21	Lower 4 bits of MPEG port. It is an input for "CCIR 656" style multiplexed Cb, Y, Cr data.
MP2	I	32	16	22	
MP1	I	33	17	23	
MP0	I	34	18	24	
RCV1	I/O	35	19	25	Raster Control 1 for video port. This pin receives/provides a VS/FS/FSEQ signal.

## Digital Video Encoder (ECO-DENC)

## SAA7124; SAA7125

SYMBOL	TYPE	PIN			DESCRIPTION
		PLCC84	LQFP64	QFP80	
RCV2	I/O	36	20	26	Raster Control 2 for video port. This pin provides an HS pulse of programmable length or receives an HS pulse.
RTCI	I	37	21	27	Real Time Control input. If the LLC clock is provided by an SAA7111 or SAA7151B, RTCI should be connected to the RTCO pin of the respective decoder to improve the signal quality.
V <sub>DD5</sub>	I	38	24	30	digital supply voltage 5
V <sub>SS5</sub>	I	39	25	31	digital ground 5
n.c.	–	40	–	35	not connected
V <sub>DD6</sub>	I	41	30	37	digital supply voltage 6
V <sub>SS6</sub>	I	42	51	39	digital ground 6
n.c.	–	43	–	40	not connected
XTALI	I	44	26	32	Crystal oscillator input (from crystal). If the oscillator is not used, this pin should be connected to ground.
XTALO	O	45	27	33	Crystal oscillator output (to crystal).
V <sub>DDO</sub>	I	46	28	34	digital supply voltage for the internal oscillator; note 1
n.c.	–	47	–	–	not connected
LLC	I/O	48	29	36	Line-Locked Clock. This is the 27 MHz master clock for the encoder. The I/O direction is set by the CDIR pin.
V <sub>DD7</sub>	I	49	52	68	digital supply voltage 7
CDIR	I	50	31	38	Clock direction. If CDIR input is HIGH, the circuit receives a clock signal, otherwise if CDIR is LOW, LLC is generated by the internal crystal oscillator.
V <sub>SS7</sub>	I	51	53	67	digital ground 7
V <sub>refL1</sub>	I	52	32	41	Lower reference voltage 1 input for DACs; connect to analog ground.
V <sub>refH1</sub>	I	53	33	42	Upper reference voltage 1 input for DACs; connect via 100 nF capacitor to analog ground.
V <sub>DDA1</sub>	I	54	34	43	Analog supply voltage 1 for DACs.
BLUE	O	55	35	44	Analog output of the BLUE component.
res	I	56	–	45	reserved
V <sub>DDA2</sub>	I	57	36	46	Analog supply voltage 2 for DACs.
GREEN	O	58	37	47	Analog output of GREEN component.
res	I	59	–	48	reserved
V <sub>DDA3</sub>	I	60	38	49	Analog supply voltage 3 for DACs.
RED	O	61	39	50	Analog output of RED component.
res	I	62	–	51	reserved
CUR1	I	63	40	52	Current input 1 for RGB amplifiers; connect via 15 kΩ resistor to V <sub>DDA</sub> .
V <sub>DDA4</sub>	I	64	41	53	Analog supply voltage 4 for DACs.
res	I	65	–	54	reserved
n.c.	–	66	–	–	not connected



## Digital Video Encoder (ECO-DENC)

## SAA7124; SAA7125

SYMBOL	TYPE	PIN			DESCRIPTION
		PLCC84	LQFP64	QFP80	
V <sub>SSA1</sub>	I	67	42	55	Analog ground 1 for the DACs.
V <sub>SSA2</sub>	I	–	43	–	Analog ground 2 for the DACs.
CUR2	I	68	44	56	Current input 2 for RGB amplifiers; connect via 15 k $\Omega$ resistor to V <sub>DDA</sub> .
res	O	69	–	57	reserved
n.c.	–	70	–	58	not connected
res	O	71	–	59	reserved
n.c.	–	72	–	60	not connected
CVBS	O	73	45	61	Analog output of the CVBS signal.
V <sub>DDA5</sub>	I	74	46	62	Analog supply voltage 5 for DACs.
V <sub>refH2</sub>	I	75	47	63	Upper reference voltage 2 input for DACs; connect via 100 nF capacitor to analog ground.
V <sub>refL2</sub>	I	76	48	64	Lower reference voltage 2 input for DACs; connect to analog ground.
AP	I	77	49	65	Test pin. Connected to digital ground for normal operation.
SP	I	78	50	66	Test pin. Connected to digital ground for normal operation.
V <sub>SSD8</sub>	I	79	58	69	digital ground 8
V <sub>DDD8</sub>	I	80	54	70	digital supply voltage 8
V <sub>SSD9</sub>	I	81	–	74	digital ground 9
V <sub>DDD9</sub>	I	82	60	76	digital supply voltage 9
SCL	I	83	55	71	I <sup>2</sup> C-bus serial clock input.
SDA	I/O	84	56	72	I <sup>2</sup> C-bus serial data input/output.

**Note**

1. V1 devices only.

Digital Video Encoder (ECO-DENC)

SAA7124; SAA7125

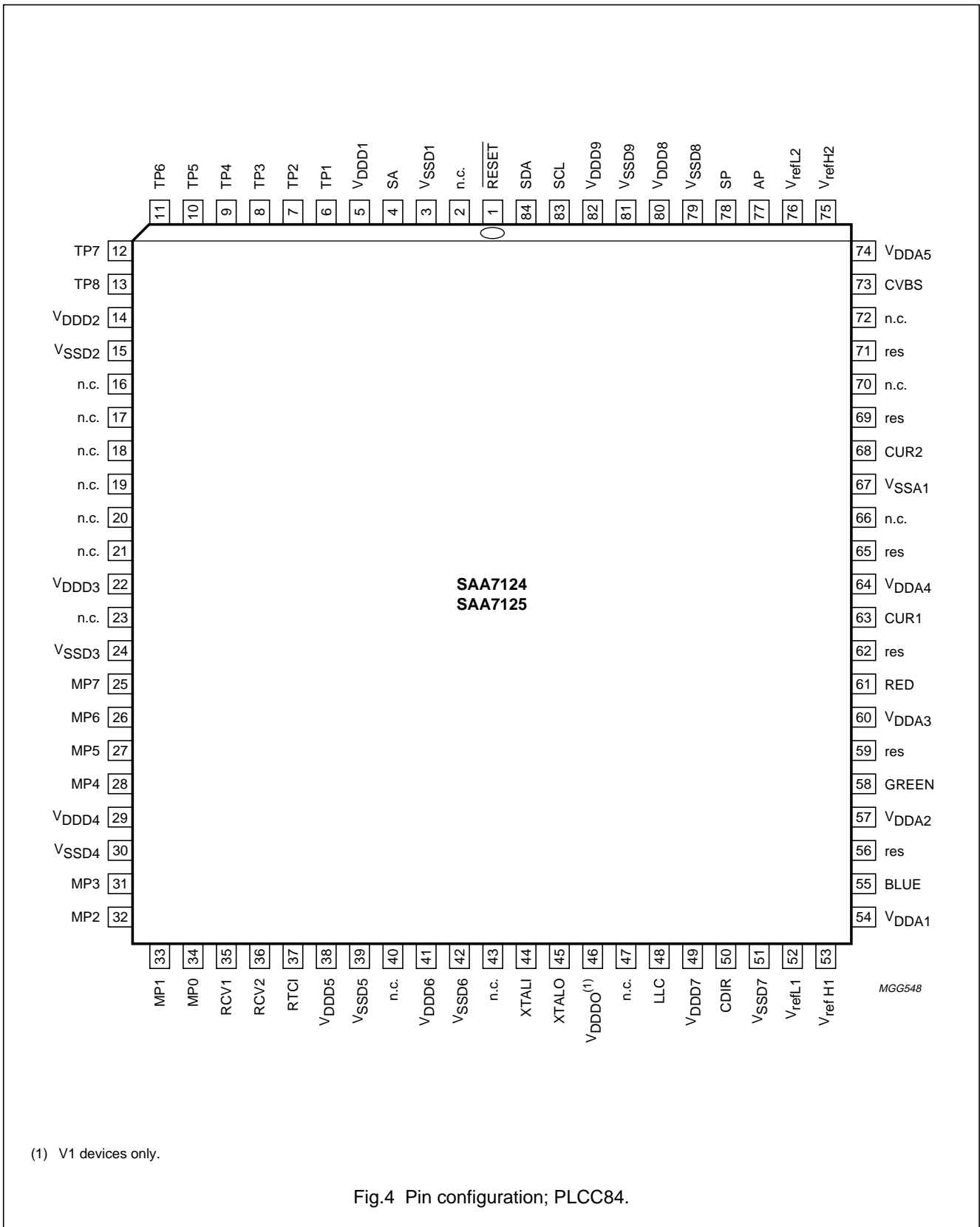

Fig.4 Pin configuration; PLCC84.

Digital Video Encoder (ECO-DENC)

SAA7124; SAA7125

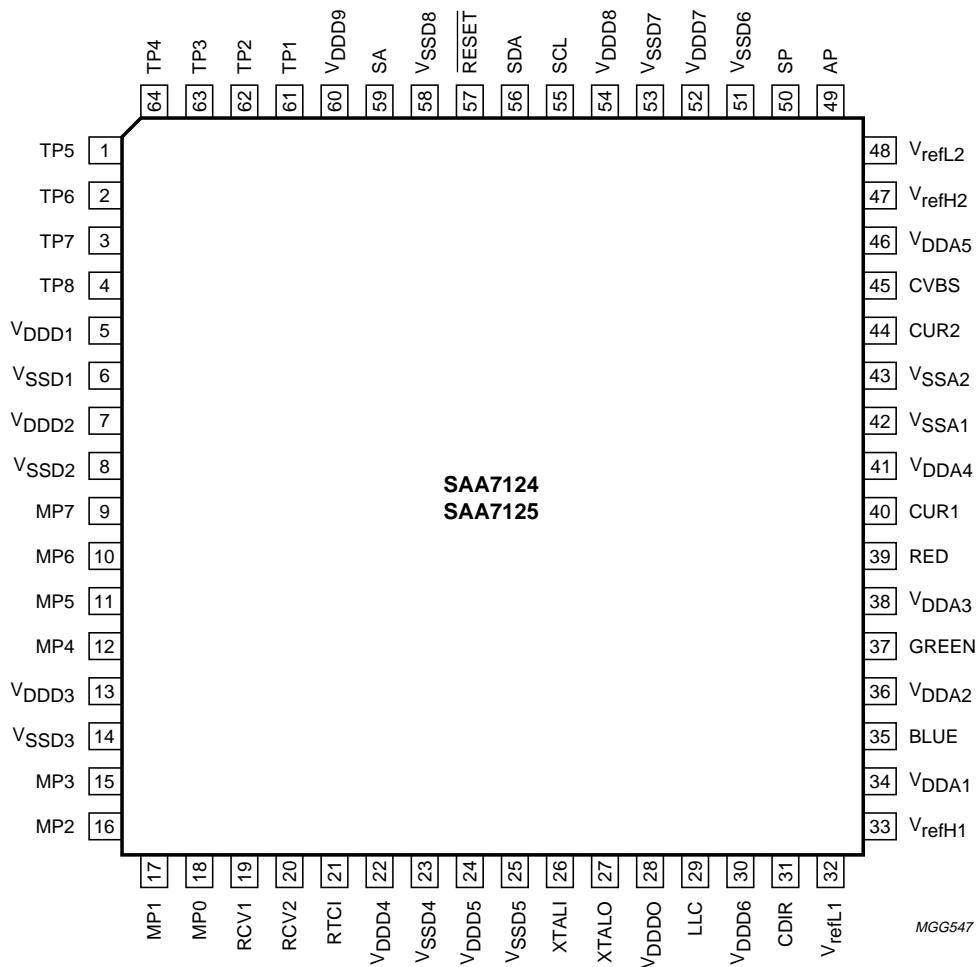
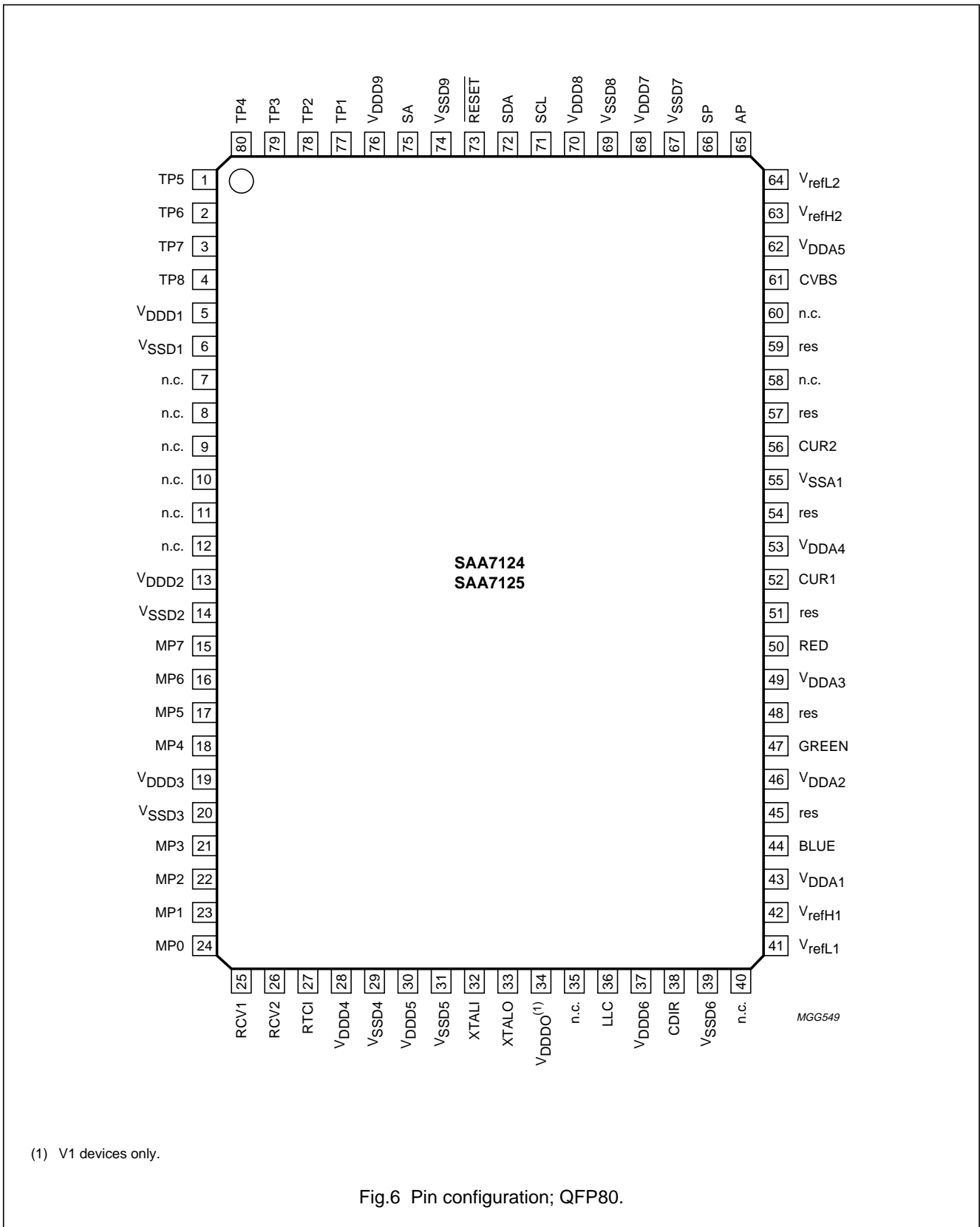

Fig.5 Pin configuration; LQFP64 (V1 devices only).

Digital Video Encoder (ECO-DENC)

SAA7124; SAA7125



## Digital Video Encoder (ECO-DENC)

## SAA7124; SAA7125

### FUNCTIONAL DESCRIPTION

The digital video encoder (ECO-DENC) encodes digital luminance and colour difference signals into analog CVBS and simultaneously RGB signals. NTSC-M, PAL B/G standards and sub-standards are supported.

Both interlaced and non-interlaced operation is possible for all standards.

Optionally, the input Y, Cb and Cr data, digital-to-analog converted, is available at the analog RGB outputs.

For applications that do not require RGB output, the device can be configured in such a way that S-Video and twice CVBS is available (Y at CVBS-DAC, C at R-DAC, and CVBS at G-DAC and B-DAC).

The basic encoder function consists of subcarrier generation, colour modulation and insertion of synchronization signals. Luminance and chrominance signals are filtered in accordance with the standard requirements of "RS-170-A" and "CCIR 624".

For ease of analog post filtering the signals are twice oversampled with respect to the pixel clock before digital-to-analog conversion.

For total filter transfer characteristics see Figs 7, 8, 9, 10, 11 and 12. The DACs for Y, C, and CVBS are realized with full 10-bit resolution, DACs for RGB with 9-bit resolution.

The MPEG port (MP) accepts 8 line multiplexed Cb, Y, Cr data.

The 8-bit multiplexed Cb-Y-Cr formats are "CCIR 656" (D1 format) compatible, but auxiliary codes such as SAV and EAV are decoded optionally for trigger purposes.

A crystal-stable master clock (LLC) of 27 MHz, which is twice the CCIR line-locked pixel clock of 13.5 MHz, needs to be supplied externally. Optionally, a crystal oscillator input/output pair of pins and an on-chip clock driver is provided.

It is also possible to connect a Philips Digital Video Decoder (SAA7111 or SAA7151B) in conjunction with a CREF clock qualifier to ECO-DENC. Via the RTCI pin, connected to RTCO of a decoder, information concerning actual subcarrier, PAL-ID, and if connected to SAA7111, definite subcarrier phase can be inserted.

The ECO-DENC synthesizes all necessary internal signals, colour subcarrier frequency, and synchronization signals, from that clock.

The encoder can be configured as slave with respect to RCV trigger inputs or auxiliary "CCIR 656" codes, or can be master to output horizontal and vertical trigger pulses.

The IC also contains Closed Caption and Extended Data Services Encoding (Line 21), and supports anti-taping signal generation in accordance with Macrovision.

A number of possibilities are provided for setting different video parameters such as:

- Black and blanking level control
- Colour subcarrier frequency
- Variable burst amplitude etc.

During reset ( $\overline{\text{RESET}} = \text{LOW}$ ) and after reset is released, all digital I/O stages are set to input mode. A reset forces the I<sup>2</sup>C-bus interface to abort any running bus transfer and sets register 3A to 03H, register 61 to 06H and registers 6BH and 6EH to 00H. All other control registers are not influenced by a reset.

### Data manager

In the data manager, real time arbitration on the data stream to be encoded is performed.

Optionally, the device can operate as a 100/75 colour bar test pattern generator without need for an external data source.

### Encoder

#### VIDEO PATH

The encoder generates out of Y, U and V baseband signals luminance and colour subcarrier output signals, suitable for use as CVBS or separate Y and C signals.

Luminance is modified in gain and in offset (latter programmable in a certain range to enable different black level set-ups). After having been inserted a fixed synchronization level, in accordance with standard composite synchronization schemes, and blanking level, programmable also in a certain range to allow for manipulations with Macrovision anti-taping, additional insertion of AGC super-white pulses, programmable in height, is supported.

In order to enable easy analog post filtering, luminance is interpolated from 13.5 MHz data rate to 27 MHz data rate, providing luminance in 10-bit resolution. This filter is also used to define smoothed transients for synchronization pulses and blanking period. For transfer characteristic of the luminance interpolation filter see Figs 9 and 10.

## Digital Video Encoder (ECO-DENC)

## SAA7124; SAA7125

Chrominance is modified in gain (programmable separately for U and V), standard dependent burst is inserted, before baseband colour signals are interpolated from 6.75 MHz data rate to 27 MHz data rate. One of the interpolation stages can be bypassed, thus providing a higher colour bandwidth, which can be made use of for Y and C output. For transfer characteristics of the chrominance interpolation filter see Figs 7 and 8.

The amplitude of inserted burst is programmable in a certain range, suitable for standard signals and for special effects. Behind the succeeding quadrature modulator, colour in 10-bit resolution is provided on subcarrier.

The numeric ratio between Y and C outputs is in accordance with set standards.

### CLOSED CAPTION ENCODER

Using this circuit, data in accordance with the specification of Closed Caption or Extended Data Service, delivered by the control interface, can be encoded (Line 21).

Two dedicated pairs of bytes (two bytes per field), each pair preceded by run-in clocks and framing code, are possible.

The actual line number where data is to be encoded in, can be modified in a certain range.

Data clock frequency is in accordance with definition for NTSC-M standard 32 times horizontal line frequency.

Data LOW at the output of the DACs corresponds to 0 IRE, data HIGH at the output of the DACs corresponds to approximately 50 IRE.

It is also possible to encode Closed Caption Data for 50 Hz field frequencies at 32 times horizontal line frequency.

### ANTI-TAPING (SAA7124 ONLY)

For more information contact your nearest Philips Semiconductors sales office.

### RGB processor

This block contains a dematrix in order to produce RED, GREEN and BLUE signals to be fed to a SCART plug.

Before Y, Cb and Cr signals are de-matrixed, 2 times oversampling for luminance and 4 times oversampling for colour difference signals is performed. For transfer curves of luminance and colour difference components of RGB see Figs 11 and 12.

### Output interface/DACs

In the output interface encoded both Y and C signals are converted from digital-to-analog in 10-bit resolution. Y and C signals are also combined to a 10-bit CVBS signal.

RED, GREEN and BLUE signals (optionally Cr, Y, Cb) are also converted from digital-to-analog, each providing a 9-bit resolution.

All output occurs with the same processing delay. Absolute amplitudes at the input of the DAC for CVBS is reduced by  $\frac{15}{16}$  with respect to Y and C DACs to make maximum use of conversion ranges.

Depending on control bits YC\_EN and DEMOFF, different signal combinations are available at DACs #1 to #4.

YC\_EN = DEMOFF = LOW is the default configuration after reset.

**Table 1** Control of DAC signals

YC_EN	DEMOFF	DAC1	DAC2	DAC3	DAC4
0	0	CVBS	R	G	B
0	1	CVBS	Cr	Y	Cb
1	0	VBS	C	CVBS	CVBS
1	1	VBS	C	CVBS	CVBS

Outputs of the DACs can be set together in two groups (#1 and #2 by DOWNB, #3 and #4 by DOWNA) via software control to minimum output voltage for either purpose.

### Synchronization

Synchronization of the ECO-DENC is able to operate in two modes; slave mode and master mode.

In the slave mode, the circuit accepts synchronization pulses at the bidirectional RCV1 port (or equivalently as frame synchronization from "CCIR 656" data stream). The timing and trigger behaviour related to RCV1 can be influenced by programming the polarity and on-chip delay of RCV1. Active slope of RCV1 defines the vertical phase and optionally the odd/even and colour frame phase to be initialized, it can be also used to set the horizontal phase.

If the horizontal phase is not to be influenced by RCV1, a horizontal pulse needs to be supplied at the RCV2 pin (or a horizontal synchronization from "CCIR 656" data stream). Timing and trigger behaviour can also be influenced for RCV2.

## Digital Video Encoder (ECO-DENC)

## SAA7124; SAA7125

If there are missing pulses at RCV1 and/or RCV2, the time base of ECO-DENC runs free, thus an arbitrary number of synchronization slopes may miss, but no additional pulses (with the incorrect phase) must occur.

If the vertical and horizontal phase is derived from RCV1, RCV2 can be used for horizontal or composite blanking input or output.

Alternatively, the device can be triggered by auxiliary codes in a "CCIR 656" data stream at the MP port.

In the master mode, the time base of the circuit continuously runs free. On the RCV1 port, the IC can output:

- A Vertical Sync signal (VS) with 3 or 2.5 lines duration, or;
- An ODD/EVEN signal which is LOW in odd fields, or;
- A field sequence signal (FSEQ) which is HIGH in the first of 4, 8 fields respectively.

On the RCV2 port, the IC can provide a horizontal pulse with programmable start and stop phase; this pulse can be inhibited in the vertical blanking period to build up, for example, a composite blanking signal.

The polarity of both RCV1 and RCV2 is selectable by software control.

Field length is in accordance with to 50 Hz or 60 Hz standards, including non-interlaced options; start and end of its active part can be programmed. The active part of a field always starts at the beginning of a line, If the standard blanking option SBLBN is not set.

**I<sup>2</sup>C-bus interface**

The I<sup>2</sup>C-bus interface is a standard slave transceiver, supporting 7-bit slave addresses and 400 kbits/s guaranteed transfer rate. It uses 8-bit subaddressing with an auto-increment function. All registers are write only, except one readable status byte.

Two I<sup>2</sup>C-bus slave addresses are selected:

88H: LOW at pin SA

8CH: HIGH at pin SA.

**Input levels and formats**

ECO-DENC expects digital Y, Cb, Cr data with levels (digital codes) in accordance with "CCIR 601".

For C and CVBS outputs, deviating amplitudes of the colour difference signals can be compensated by independent gain control setting, while gain for luminance is set to predefined values, distinguishable for 7.5 IRE set-up or without set-up.

For RGB (or Y, Cb and Cr) outputs fixed amplification in accordance with "CCIR 601" is provided.

Reference levels are measured with a colour bar, 100% white, 100% amplitude and 100% saturation.

**TRANSFORMATION**

$$R = Y + 1.3707 \times (Cr - 128)$$

$$G = Y - 0.3365 \times (Cb - 128) - 0.6982 \times (Cr - 128)$$

$$B = Y + 1.7324 \times (Cb - 128).$$

Representation of R, G and B at the output is 9 bits at 27 MHz.

**Table 2** 8-bit multiplexed format (similar to "CCIR 656")

TIME	BITS							
	0	1	2	2	4	5	6	7
Sample	Cb <sub>0</sub>	Y <sub>0</sub>	Cr <sub>0</sub>	Y <sub>1</sub>	Cb <sub>2</sub>	Y <sub>2</sub>	Cr <sub>2</sub>	Y <sub>3</sub>
Luminance pixel number	0		1		2		3	
Colour pixel number	0				2			

## Digital Video Encoder (ECO-DENC)

SAA7124; SAA7125

## Bit allocation map

Table 3 Slave receiver (slave address 88H or 8CH)

REGISTER FUNCTION	SUB ADDRESS	DATA BYTE <sup>(1)</sup>							
		D7	D6	D5	D4	D3	D2	D1	D0
Null	00	0	0	0	0	0	0	0	0
↓									
Null	39	0	0	0	0	0	0	0	0
I/O port control	3A	CBENB	0	YC_EN	SYMP	DEMOFF	0	Y2C	UV2C
Null	42	0	0	0	0	0	0	0	0
↓									
Null	59	0	0	0	0	0	0	0	0
Chrominance phase	5A	CHPS7	CHPS6	CHPS5	CHPS4	CHPS3	CHPS2	CHPS1	CHPS0
Gain U	5B	GAINU7	GAINU6	GAINU5	GAINU4	GAINU3	GAINU2	GAINU1	GAINU0
Gain V	5C	GAINV7	GAINV6	GAINV5	GAINV4	GAINV3	GAINV2	GAINV1	GAINV0
Gain U MSB, black level	5D	GAINU8	0	BLCKL5	BLCKL4	BLCKL3	BLCKL2	BLCKL1	BLCKL0
Gain V MSB, blanking level, decoder type	5E	GAINV8	DECTYP	BLNNL5	BLNNL4	BLNNL3	BLNNL2	BLNNL1	BLNNL0
Blanking level VBI	5F	0	0	BLNVB5	BLNVB4	BLNVB3	BLNVB2	BLNVB1	BLNVB0
Null	60	0	0	0	0	0	0	0	0
Standard control	61	DOWNB	DOWNA	INPI	YGS	0	SCBW	PAL	FISE
RTC enable burst amplitude	62	RTCE	BSTA6	BSTA5	BSTA4	BSTA3	BSTA2	BSTA1	BSTA0
Subcarrier 0	63	FSC07	FSC06	FSC05	FSC04	FSC03	FSC02	FSC01	FSC00
Subcarrier 1	64	FSC15	FSC14	FSC13	FSC12	FSC11	FSC10	FSC09	FSC08
Subcarrier 2	65	FSC23	FSC22	FSC21	FSC20	FSC19	FSC18	FSC17	FSC16
Subcarrier 3	66	FSC31	FSC30	FSC29	FSC28	FSC27	FSC26	FSC25	FSC24
Line 21 odd 0	67	L21O07	L21O06	L21O05	L21O04	L21O03	L21O02	L21O01	L21O00
Line 21 odd 1	68	L21O17	L21O16	L21O15	L21O14	L21O13	L21O12	L21O11	L21O10
Line 21 even 0	69	L21E07	L21E06	L21E05	L21E04	L21E03	L21E02	L21E01	L21E00
Line 21 even 1	6A	L21E17	L21E16	L21E15	L21E14	L21E13	L21E12	L21E11	L21E10
RCV port control	6B	SRCV11	SRCV10	TRCV2	ORCV1	PRCV1	CBLF	ORCV2	PRCV2
Trigger control	6C	HTRIG7	HTRIG6	HTRIG5	HTRIG4	HTRIG3	HTRIG2	HTRIG1	HTRIG0
Trigger control	6D	HTRIG10	HTRIG9	HTRIG8	VTRIG4	VTRIG3	VTRIG2	VTRIG1	VTRIG0
Multi control	6E	SBLBN	0	PHRES1	PHRES0	0	0	FLC1	FLCO



## Digital Video Encoder (ECO-DENC)

SAA7124; SAA7125

REGISTER FUNCTION	SUB ADDRESS	DATA BYTE <sup>(1)</sup>							
		D7	D6	D5	D4	D3	D2	D1	D0
Closed caption	6F	CCEN1	CCEN0	0	SCCLN4	SCCLN3	SCCLN2	SCCLN1	SCCLN0
RCV2 output start	70	RCV2S7	RCV2S6	RCV2S5	RCV2S4	RCV2S3	RCV2S2	RCV2S1	RCV2S0
RCV2 output end	71	RCV2E7	RCV2E6	RCV2E5	RCV2E4	RCV2E3	RCV2E2	RCV2E1	RCV2E0
MSBs RCV2 output	72	0	RCV2E10	RCV2E9	RCV2E8	0	RCV2S10	RCV2S9	RCV2S8
Null	73	0	0	0	0	0	0	0	0
Null	74	0	0	0	0	0	0	0	0
Null	75	0	0	0	0	0	0	0	0
Null	76	0	0	0	0	0	0	0	0
Null	77	0	0	0	0	0	0	0	0
Null	78	0	0	0	0	0	0	0	0
Null	79	0	0	0	0	0	0	0	0
First active line	7A	FAL7	FAL6	FAL5	FAL4	FAL3	FAL2	FAL1	FAL0
Last active line	7B	LAL7	LAL6	LAL5	LAL4	LAL3	LAL2	LAL1	LAL0
MSBs vertical	7C	0	LAL8	0	FAL8	0	0	0	0
Null	7D	0	0	0	0	0	0	0	0
Null	7E	0	0	0	0	0	0	0	0
Null	7F	0	0	0	0	0	0	0	0

**Note**

1. All bits marked 0 must be programmed to zero.

## Digital Video Encoder (ECO-DENC)

## SAA7124; SAA7125

**I<sup>2</sup>C-bus format****Table 4** I<sup>2</sup>C-bus address; see Table 5

S	SLAVE ADDRESS	ACK	SUBADDRESS	ACK	DATA 0	ACK	-----	DATA n	ACK	P
---	---------------	-----	------------	-----	--------	-----	-------	--------	-----	---

**Table 5** Explanation of Table 4

PART	DESCRIPTION
S	START condition
Slave address	1 0 0 0 1 0 0 X or 1 0 0 0 1 1 0 X (note 1)
ACK	acknowledge, generated by the slave
Subaddress (note 2)	subaddress byte
DATA	data byte
-----	continued data bytes and ACKs
P	STOP condition

**Notes**

1. X is the read/write control bit; X = logic 0 is order to write; X = logic 1 is order to read, no subaddressing with read.
2. If more than 1 byte DATA is transmitted, then auto-increment of the subaddress is performed.

**Slave Receiver****Table 6** Subaddress 3A

DATA BYTE	LOGIC LEVEL	DESCRIPTION
UV2C	0	Cb, Cr data are two's complement.
	1	Cb, Cr data are straight binary. Default after reset.
Y2C	0	Y data is two's complement.
	1	Y data is straight binary. Default after reset.
DEMOFF	0	Y, Cb and Cr for RGB dematrix is active. Default after reset.
	1	Y, Cb and Cr for RGB dematrix is bypassed.
SYMP	0	Horizontal and vertical trigger is taken from RCV2 and RCV1 respectively. Default after reset.
	1	Horizontal and vertical trigger is decoded out of "CCIR 656" compatible data at MP port.
YC_EN	0	Output of CVBS and RGB signals. Default after reset.
	1	Output of Y, C, and CVBS, CVBS signals.
CBENB	0	Data from input ports is encoded. Default after reset.
	1	Colour bar with fixed colours is encoded. The LUTs are read in upward order from index 0 to index 7.

## Digital Video Encoder (ECO-DENC)

## SAA7124; SAA7125

**Table 7** Subaddress 5A

DATA BYTE	DESCRIPTION	VALUE	RESULT
CHPS	phase of encoded colour subcarrier (including burst) relative to horizontal sync. Can be adjusted in steps of 360/256 degrees	tbf	PAL-B/G and data from input ports
		tbf	PAL-B/G and data from look-up table
		tbf	NTSC-M and data from input ports
		tbf	NTSC-M and data from look-up table

**Table 8** Subaddress 5B and 5D

DATA BYTE	DESCRIPTION	CONDITIONS	REMARKS
GAINU	variable gain for Cb signal; input representation accordance with "CCIR 601"	white-to-black = 92.5 IRE <sup>(1)</sup> GAINU = 0 GAINU = 118 (76H)	output subcarrier of U contribution = 0 output subcarrier of U contribution = nominal
		white-to-black = 100 IRE <sup>(2)</sup> GAINU = 0 GAINU = 125 (7DH)	output subcarrier of U contribution = 0 output subcarrier of U contribution = nominal

**Notes**

1.  $GAINU = -2.17 \times \text{nominal}$  to  $+2.16 \times \text{nominal}$ .
2.  $GAINU = -2.05 \times \text{nominal}$  to  $+2.04 \times \text{nominal}$ .

**Table 9** Subaddress 5C and 5E

DATA BYTE	DESCRIPTION	CONDITIONS	REMARKS
GAINV	variable gain for Cr signal; input representation accordance with "CCIR 601"	white-to-black = 92.5 IRE <sup>(1)</sup> GAINV = 0 GAINV = 165 (A5H)	output subcarrier of V contribution = 0 output subcarrier of V contribution = nominal
		white-to-black = 100 IRE <sup>(2)</sup> GAINV = 0 GAINV = 175 (AFH)	output subcarrier of V contribution = 0 output subcarrier of V contribution = nominal

**Notes**

1.  $GAINV = -1.55 \times \text{nominal}$  to  $+1.55 \times \text{nominal}$ .
2.  $GAINV = -1.46 \times \text{nominal}$  to  $+1.46 \times \text{nominal}$ .

## Digital Video Encoder (ECO-DENC)

## SAA7124; SAA7125

Table 10 Subaddress 5D

DATA BYTE	DESCRIPTION	CONDITIONS	REMARKS
BLCKL	variable black level; input representation accordance with "CCIR 601"	white-to-sync = 140 IRE <sup>(1)</sup> BLCKL = 0 BLCKL = 63 (3FH)	output black level = 24 IRE output black level = 49 IRE
		white-to-sync = 143 IRE <sup>(2)</sup> BLCKL = 0 BLCKL = 63 (3FH)	output black level = 24 IRE output black level = 50 IRE

## Notes

1. Output black level/IRE =  $BLCKL \times 25/63 + 24$ ; recommended value: BLCKL = 60 (3CH) normal.
2. Output black level/IRE =  $BLCKL \times 26/63 + 24$ ; recommended value: BLCKL = 45 (2DH) normal.

Table 11 Subaddress 5E

DATA BYTE	DESCRIPTION	CONDITIONS	REMARKS
BLNNL	variable blanking level	white-to-sync = 140 IRE <sup>(1)</sup> BLNNL = 0 BLNNL = 63 (3FH)	output blanking level = 17 IRE output blanking level = 42 IRE
		white-to-sync = 143 IRE <sup>(2)</sup> BLNNL = 0 BLNNL = 63 (3FH)	output blanking level = 17 IRE output blanking level = 43 IRE
DECTYP	RTCI	logic 0	real time control input from SAA7151B
		logic 1	real time control input from SAA7111

## Notes

1. Output black level/IRE =  $BLNNL \times 25/63 + 17$ ; recommended value: BLNNL = 58 (3AH) normal.
2. Output black level/IRE =  $BLNNL \times 26/63 + 17$ ; recommended value: BLNNL = 63 (3FH) normal.

Table 12 Subaddress 5F

DATA BYTE	DESCRIPTION
BLNVB	variable blanking level during vertical blanking interval is typically identical to value of BLNNL

## Digital Video Encoder (ECO-DENC)

## SAA7124; SAA7125

Table 13 Subaddress 61

DATA BYTE	LOGIC LEVEL	DESCRIPTION
FISE	0	864 total pixel clocks per line; default after reset
	1	858 total pixel clocks per line
PAL	0	NTSC encoding (non-alternating V component)
	1	PAL encoding (alternating V component); default after reset
SCBW	0	enlarged bandwidth for chrominance encoding (for overall transfer characteristic of chrominance in baseband representation see Figs 7 and 8)
	1	standard bandwidth for chrominance encoding (for overall transfer characteristic of chrominance in baseband representation see Figs 7 and 8); default after reset
YGS	0	luminance gain for white – black 100 IRE; default after reset
	1	luminance gain for white – black 92.5 IRE including 7.5 IRE set-up of black
INPI	0	PAL switch phase is nominal; default after reset
	1	PAL switch phase is inverted compared to nominal
DOWNA	0	DACs for G and B (Y and Cb or CVBS and CVBS) in normal operational mode; default after reset
	1	DACs for G and B (Y and Cb or CVBS and CVBS) forced to lowest output voltage
DOWNB	0	DACs for CVBS and R (CVBS and Cr or VBS and C) in normal operational mode; default after reset
	1	DACs for CVBS and R (CVBS and Cr or VBS and C) forced to lowest output voltage

Table 14 Subaddress 62A

DATA BYTE	DESCRIPTION	CONDITIONS	REMARKS
BSTA	amplitude of colour burst; input representation in accordance with "CCIR 601"	white-to-black = 92.5 IRE; burst = 40 IRE; NTSC encoding BSTA = 0 to $1.25 \times$ nominal	recommended value: BSTA = 102 (66H)
		white-to-black = 92.5 IRE; burst = 40 IRE; PAL encoding BSTA = 0 to $1.76 \times$ nominal	recommended value: BSTA = 72 (48H)
		white-to-black = 100 IRE; burst = 43 IRE; NTSC encoding BSTA = 0 to $1.20 \times$ nominal	recommended value: BSTA = 106 (6AH)
		white-to-black = 100 IRE; burst = 43 IRE; PAL encoding BSTA = 0 to $1.67 \times$ nominal	recommended value: BSTA = 75 (4BH)

Table 15 Subaddress 62B

DATA BYTE	LOGIC LEVEL	DESCRIPTION
RTCE	0	no real time control of generated subcarrier frequency
	1	real time control of generated subcarrier frequency through SAA7151B or SAA7111 (timing see Fig.15)

## Digital Video Encoder (ECO-DENC)

## SAA7124; SAA7125

**Table 16** Subaddress 63 to 66 (four bytes to program subcarrier frequency)

DATA BYTE	DESCRIPTION	CONDITIONS	REMARKS
FSC0 to FSC3	$f_{fsc}$ = subcarrier frequency (in multiples of line frequency); $f_{llc}$ = clock frequency (in multiples of line frequency)	$FSC = \text{round}\left(\frac{f_{fsc}}{f_{llc}} \times 2^{32}\right)$ see note 1	FSC3 = most significant byte FSC0 = least significant byte

**Note**

## 1. Examples:

- a) NTSC-M:  $f_{fsc} = 227.5$ ,  $f_{llc} = 1716 \rightarrow FSC = 569408543$  (21F07C1FH).
- b) PAL-B/G:  $f_{fsc} = 283.7516$ ,  $f_{llc} = 1728 \rightarrow FSC = 705268427$  (2A098ACBH).

**Table 17** Subaddress 67 to 6A

DATA BYTE	DESCRIPTION	REMARK
L21O0	first byte of captioning data, odd field	LSB of the respective bytes are encoded immediately after run-in and framing code, the MSBs of the respective bytes have to carry the parity bit, in accordance with the definition of Line 21 encoding format
L21O1	second byte of captioning data, odd field	
L21E0	first byte of extended data, even field	
L21E1	second byte of extended data, even field	

## Digital Video Encoder (ECO-DENC)

## SAA7124; SAA7125

Table 18 Subaddress 6B

DATA BYTE	LOGIC LEVEL	DESCRIPTION
PRCV2	0	polarity of RCV2 as output is active HIGH, rising edge is taken when input, respectively; default after reset
	1	polarity of RCV2 as output is active LOW, falling edge is taken when input, respectively
ORCV2	0	pin RCV2 is switched to input; default after reset
	1	pin RCV2 is switched to output
CBLF	0	if ORCV2 = HIGH, pin RCV2 provides an HREF signal (Horizontal Reference pulse that is defined by RCV2S and RCV2E, also during vertical blanking Interval); default after reset  if ORCV2 = LOW and bit SYMP = LOW, signal input to RCV2 is used for horizontal synchronization only (if TRCV2 = HIGH); default after reset
	1	if ORCV2 = HIGH, pin RCV2 provides a 'Composite-Blanking-Not' signal, this is a reference pulse that is defined by RCV2S and RCV2E, excluding Vertical Blanking Interval, which is defined by FAL and LAL  if ORCV2 = LOW and bit SYMP = LOW, signal input to RCV2 is used for horizontal synchronization (if TRCV2 = HIGH) and as an internal blanking signal
PRCV1	0	polarity of RCV1 as output is active HIGH, rising edge is taken when input; default after reset
	1	polarity of RCV1 as output is active LOW, falling edge is taken when input
ORCV1	0	pin RCV1 is switched to input; default after reset
	1	pin RCV1 is switched to output
TRCV2	0	horizontal synchronization is taken from RCV1 port (at bit SYMP = LOW) or from decoded frame sync of "CCIR 656" input (at bit SYMP = HIGH); default after reset
	1	horizontal synchronization is taken from RCV2 port (at bit SYMP = LOW)
SRCV1	–	defines signal type on pin RCV1; see Table 19

Table 19 Logic levels and function of SRCV1

DATA BYTE		AS OUTPUT	AS INPUT	FUNCTION
SRCV11	SRCV10			
0	0	VS	VS	vertical sync each field; default after reset
0	1	FS	FS	frame sync (odd/even)
1	0	FSEQ	FSEQ	field sequence, vertical sync every fourth field (PAL = 0) or eighth field (PAL = 1)
1	1	not applicable	not applicable	–

## Digital Video Encoder (ECO-DENC)

## SAA7124; SAA7125

**Table 20** Subaddress 6C and 6D

DATA BYTE	DESCRIPTION
HTRIG	sets the horizontal trigger phase related to signal on RCV1 or RCV2 input (or to decoded "CCIR 656" data) values above 1715 (FISE = 1) or 1727 (FISE = 0) are not allowed increasing HTRIG decreases delays of all internally generated timing signals reference mark: analog output horizontal sync (leading slope) coincides with active edge of RCV used for triggering at HTRIG = tbfH (tbfH)

**Table 21** Subaddress 6D

DATA BYTE	DESCRIPTION
VTRIG	sets the vertical trigger phase related to signal on RCV1 input (or to decoded "CCIR 656" data) increasing VTRIG decreases delays of all internally generated timing signals, measured in half lines variation range of VTRIG = 0 to 31 (1FH)

**Table 22** Subaddress 6E

DATA BYTE	LOGIC LEVEL	DESCRIPTION
SBLBN	0	vertical blanking is defined by programming of FAL and LAL; default after reset
	1	vertical blanking is forced in accordance with "CCIR 624" (50 Hz) or "RS170A" (60 Hz)
PHRES	–	selects the phase reset mode of the colour subcarrier generator; see Table 23
FLC	–	field length control; see Table 24

**Table 23** Logic levels and function of PHRES

DATA BYTE		FUNCTION
PHRES1	PHRES0	
0	0	no reset or reset via RTCI from SAA7111 if bit RTCE = 1; default after reset
0	1	reset every two lines
1	0	reset every eight fields
1	1	reset every four fields

**Table 24** Logic levels and function of FLC

DATA BYTE		FUNCTION
FLC1	FLC0	
0	0	interlaced 312.5 lines/field at 50 Hz, 262.5 lines/field at 60 Hz; default after reset
0	1	non-interlaced 312 lines/field at 50 Hz, 262 lines/field at 60 Hz
1	0	non-interlaced 313 lines/field at 50 Hz, 263 lines/field at 60 Hz
1	1	non-interlaced 313 lines/field at 50 Hz, 263 lines/field at 60 Hz



## Digital Video Encoder (ECO-DENC)

## SAA7124; SAA7125

**Table 25** Subaddress 6F

DATA BYTE	DESCRIPTION
CCEN	enables individual Line 21 encoding; see Table 26
SCCLN	selects the actual line, where closed caption or extended data are encoded line = (SCCLN + 4) for M-systems line = (SCCLN + 1) for other systems

**Table 26** Logic levels and function of CCEN

DATA BYTE		FUNCTION
CCEN1	CCEN0	
0	0	line 21 encoding off
0	1	enables encoding in field 1 (odd)
1	0	enables encoding in field 2 (even)
1	1	enables encoding in both fields

**Table 27** Subaddress 70 to 72

DATA BYTE	DESCRIPTION
RCV2S	start of output signal on RCV2 pin values above 1715 (FISE = 1) or 1727 (FISE = 0) are not allowed first active pixel at analog outputs (corresponding input pixel coinciding with RCV2) at RCV2S = tbfH (tbfH)
RCV2E	end of output signal on RCV2 pin values above 1715 (FISE = 1) or 1727 (FISE = 0) are not allowed last active pixel at analog outputs (corresponding input pixel coinciding with RCV2) at RCV2E = tbfH (tbfH)

**Table 28** Subaddress 7A to 7C

DATA BYTE	DESCRIPTION
FAL	first active line = FAL + 4 for M-systems, = FAL + 1 for other systems, measured in lines FAL = 0 coincides with the first field synchronization pulse
LAL	last active line = LAL + 3 for M-systems, = LAL for other system, measured in lines LAL = 0 coincides with the first field synchronization pulse

## SUBADDRESSES

In subaddresses 5B, 5C, 5D, 5E and 62 all IRE values are rounded up.

## Digital Video Encoder (ECO-DENC)

## SAA7124; SAA7125

## Slave Transmitter

Table 29 Slave transmitter (slave address 89H or 8DH)

REGISTER FUNCTION	SUBADDRESS	DATA BYTE							
		D7	D6	D5	D4	D3	D2	D1	D0
Status byte	–	VER2	VER1	VER0	CCRDO	CCRDE	0	FSEQ	O_E

Table 30 No subaddress

DATA BYTE	LOGIC LEVEL	DESCRIPTION
VER	–	Version identification of the device. It will be changed with all versions of the IC that have different programming models. Current Version is 100 binary.
CCRDO	1	Closed caption bytes of the odd field have been encoded.
	0	The bit is reset after information has been written to the subaddresses 67 and 68. It is set immediately after the data has been encoded.
CCRDE	1	Closed caption bytes of the even field have been encoded.
	0	The bit is reset after information has been written to the subaddresses 69 and 6A. It is set immediately after the data has been encoded.
FSEQ	1	During first field of a sequence (repetition rate: NTSC = 4 fields, PAL = 8 fields.
	0	Not first field of a sequence.
O_E	1	During even field.
	0	During odd field.

Digital Video Encoder (ECO-DENC)

SAA7124; SAA7125

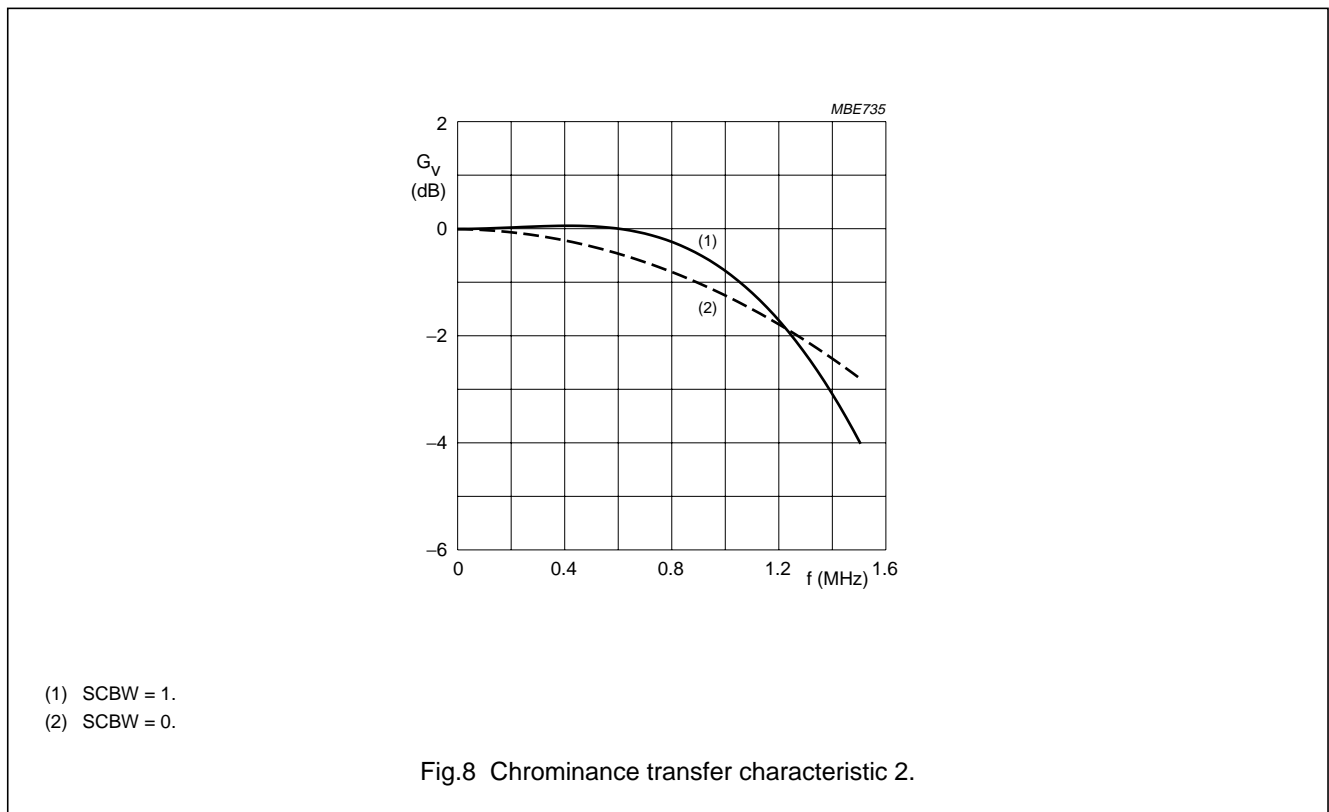
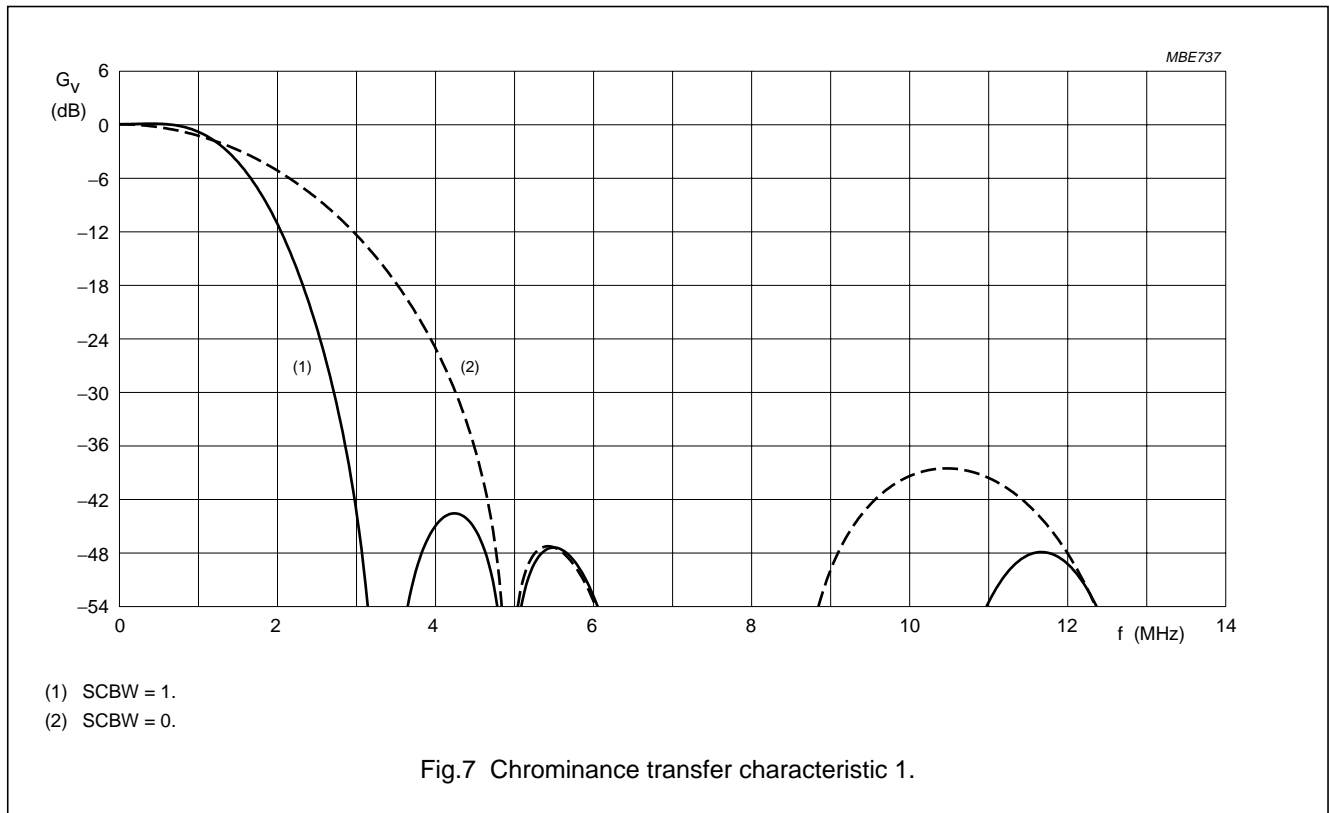

Digital Video Encoder (ECO-DENC)

SAA7124; SAA7125

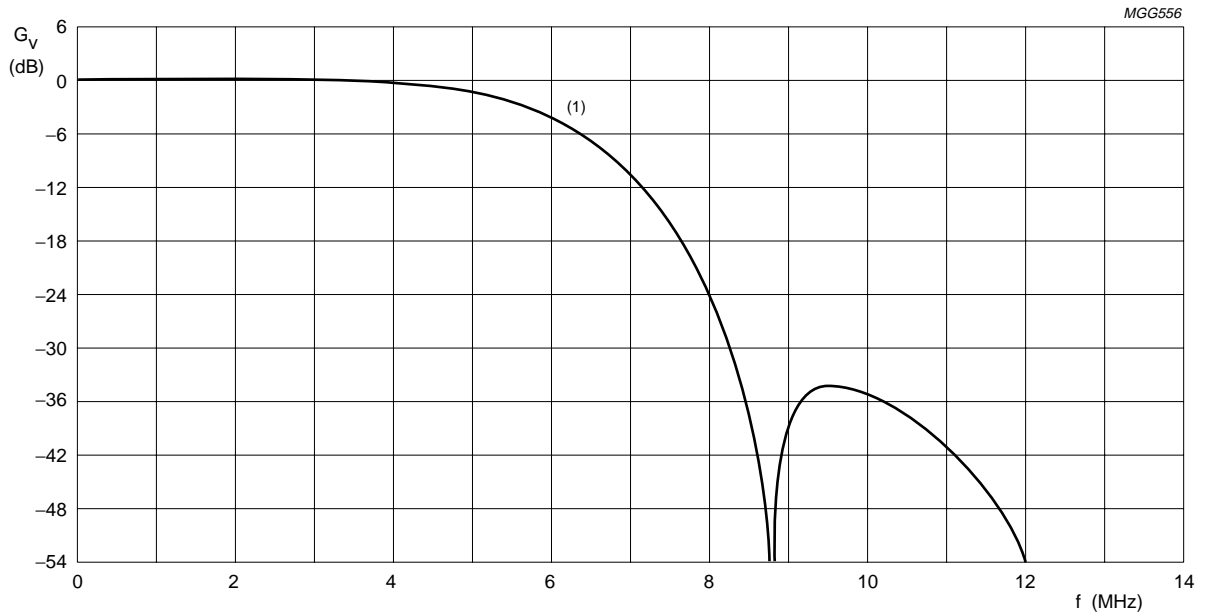

(1) Total luminance of Y and CVBS.

Fig.9 Luminance transfer characteristic 1.

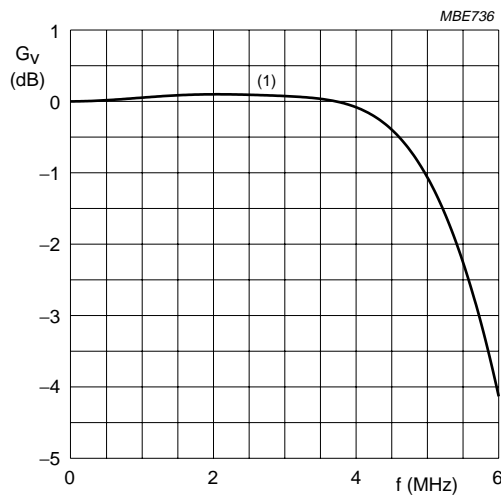

(1) Detailed luminance of Y and CVBS.

Fig.10 Luminance transfer characteristic 2.

Digital Video Encoder (ECO-DENC)

SAA7124; SAA7125

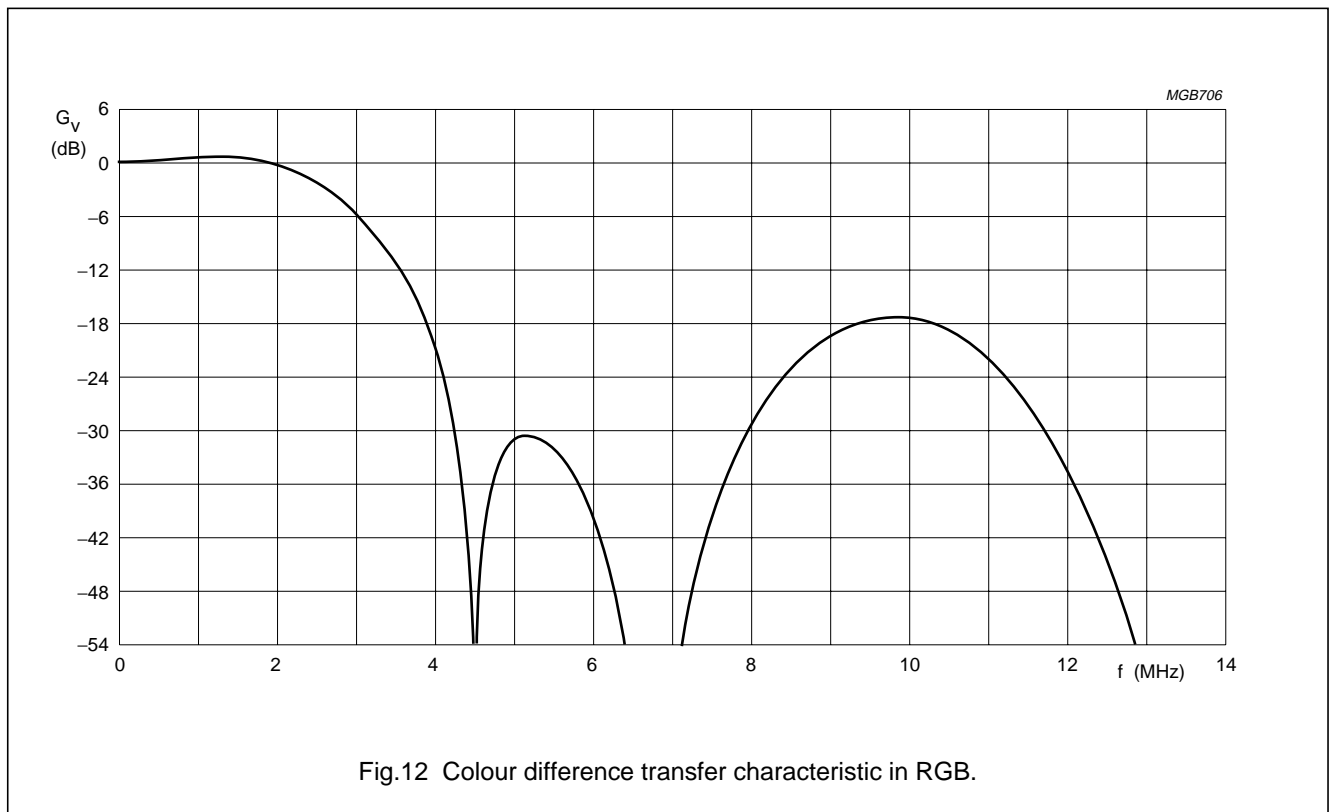
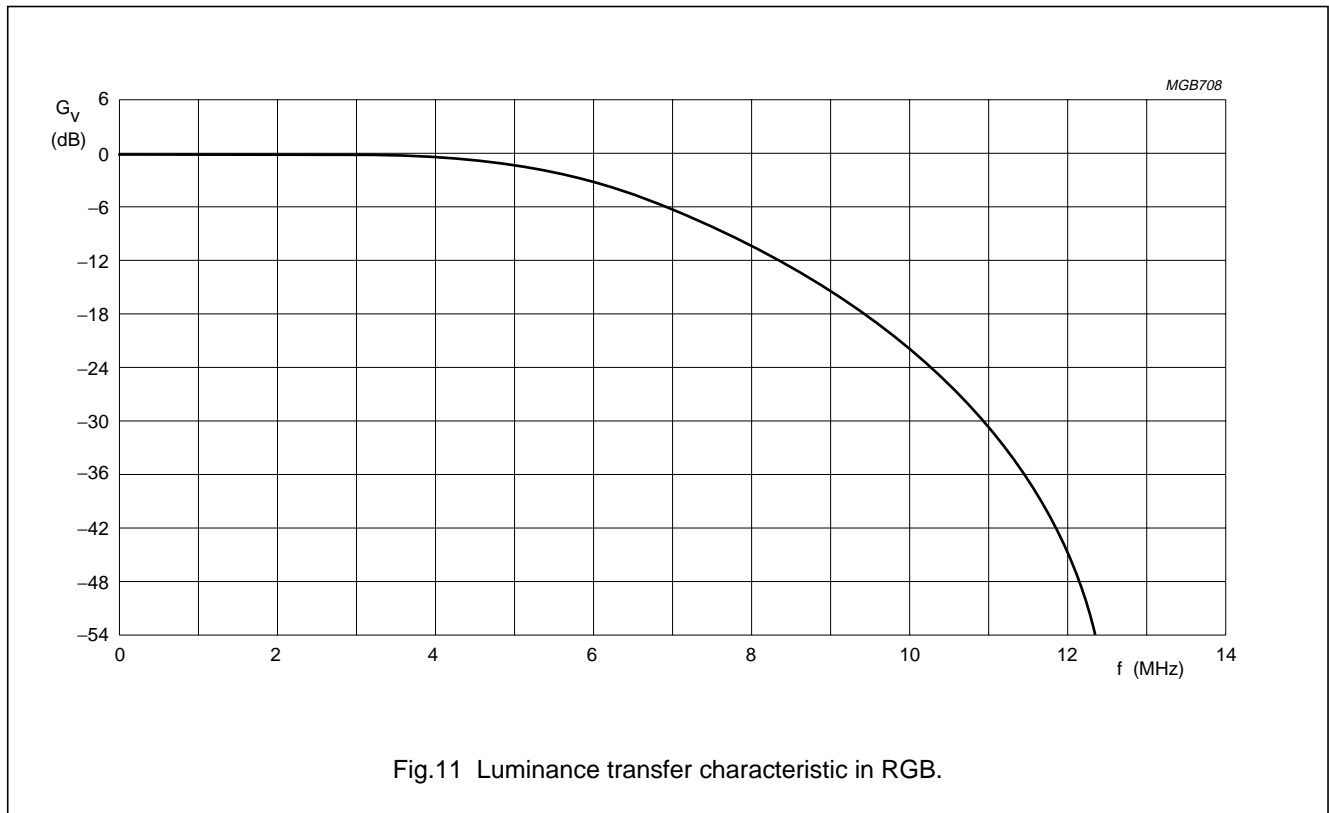

## Digital Video Encoder (ECO-DENC)

## SAA7124; SAA7125

**CHARACTERISTICS**

$V_{DD} = 4.75$  to  $5.25$  V;  $T_{amb} = 0$  to  $+70$  °C; unless otherwise specified.

SYMBOL	PARAMETER	CONDITIONS	MIN.	MAX.	UNIT
<b>Supplies</b>					
$V_{DDA}$	analog supply voltage		4.75	5.25	V
$V_{DDD}$	digital supply voltage		4.75	5.25	V
$I_{DDA}$	analog supply current	note 1	–	60	mA
$I_{DDD}$	digital supply current	note 1	–	100	mA
<b>Inputs</b>					
$V_{IL}$	LOW level input voltage (except SDA, SCL, AP, SP and XTALI)		–0.5	+0.8	V
$V_{IH}$	HIGH level input voltage (except LLC, SDA, SCL, AP, SP and XTALI)		2.0	$V_{DDD} + 0.5$	V
	HIGH level input voltage (LLC)		2.4	$V_{DDD} + 0.5$	V
$I_{LI}$	input leakage current		–	1	µA
$C_i$	input capacitance	clocks	–	10	pF
		data	–	8	pF
		I/Os at high impedance	–	8	pF
<b>Outputs</b>					
$V_{OL}$	LOW level output voltage (except SDA and XTALO)	note 2	0	0.6	V
$V_{OH}$	HIGH level output voltage (except LLC, SDA, and XTALO)	note 2	2.4	$V_{DDD} + 0.5$	V
	HIGH level output voltage (LLC)	note 2	2.6	$V_{DDD} + 0.5$	V
<b>I<sup>2</sup>C-bus; SDA and SCL</b>					
$V_{IL}$	LOW level input voltage		–0.5	+1.5	V
$V_{IH}$	HIGH level input voltage		3.0	$V_{DDD} + 0.5$	V
$I_i$	input current	$V_i = \text{LOW or HIGH}$	–10	+10	µA
$V_{OL}$	LOW level output voltage (SDA)	$I_{OL} = 3$ mA	–	0.4	V
$I_o$	output current	during acknowledge	3	–	mA
<b>Clock timing (LLC)</b>					
$T_{LLC}$	cycle time	note 3	34	41	ns
$\delta$	duty factor $t_{HIGH}/T_{LLC}$	note 4	40	60	%
$t_r$	rise time	note 3	–	5	ns
$t_f$	fall time	note 3	–	6	ns
<b>Input timing</b>					
$t_{SU;DAT}$	input data set-up time (any other except CDIR, SCL, SDA, RESET, AP and SP)		6	–	ns
$t_{HD;DAT}$	input data hold time (any other except CDIR, SCL, SDA, RESET, AP and SP)		3	–	ns

## Digital Video Encoder (ECO-DENC)

## SAA7124; SAA7125

SYMBOL	PARAMETER	CONDITIONS	MIN.	MAX.	UNIT
<b>Crystal oscillator</b>					
$f_n$	nominal frequency (usually 27 MHz)	3rd harmonic	–	30	MHz
$\Delta f/f_n$	permissible deviation of nominal frequency	note 5	–50	+50	$10^{-6}$
CRYSTAL SPECIFICATION					
$T_{amb}$	operating ambient temperature		0	70	°C
$C_L$	load capacitance		8	–	pF
$R_S$	series resistance		–	80	$\Omega$
$C_1$	motional capacitance (typical)		1.5 – 20%	1.5 + 20%	fF
$C_0$	parallel capacitance (typical)		3.5 – 20%	3.5 + 20%	pF
<b>Data and reference signal output timing</b>					
$C_L$	output load capacitance		7.5	40	pF
$t_h$	output hold time		4	–	ns
$t_d$	output delay time		–	25	ns
<b>CHROMA, Y, CVBS and RGB outputs</b>					
$V_{o(p-p)}$	output signal voltage (peak-to-peak value)	note 6	1.9	2.1	V
$R_{int}$	internal serial resistance		18	35	$\Omega$
$R_L$	output load resistance		80	–	$\Omega$
B	output signal bandwidth of DACs	–3 dB	10	–	MHz
ILE	LF integral linearity error of DACs		–	$\pm 4$	LSB
DLE	LF differential linearity error of DACs		–	$\pm 1$	LSB

**Notes**

1. At maximum supply voltage with highly active input signals.
2. The levels have to be measured with load circuits of 1.2 k $\Omega$  to 3.0 V (standard TTL load) and  $C_L = 25$  pF.
3. The data is for both input and output direction.
4. With LLC in input mode. In output mode, with a crystal connected to XTALO/XTALI duty factor is typically 50%.
5. If an internal oscillator is used, crystal deviation of nominal frequency is directly proportional to the deviation of subcarrier frequency and line/field frequency.
6. For full digital range, without load,  $V_{DDA} = 5.0$  V. The typical voltage swing is 2.0 V, the typical minimum output voltage (digital zero at DAC) is 0.2 V.

Digital Video Encoder (ECO-DENC)

SAA7124; SAA7125

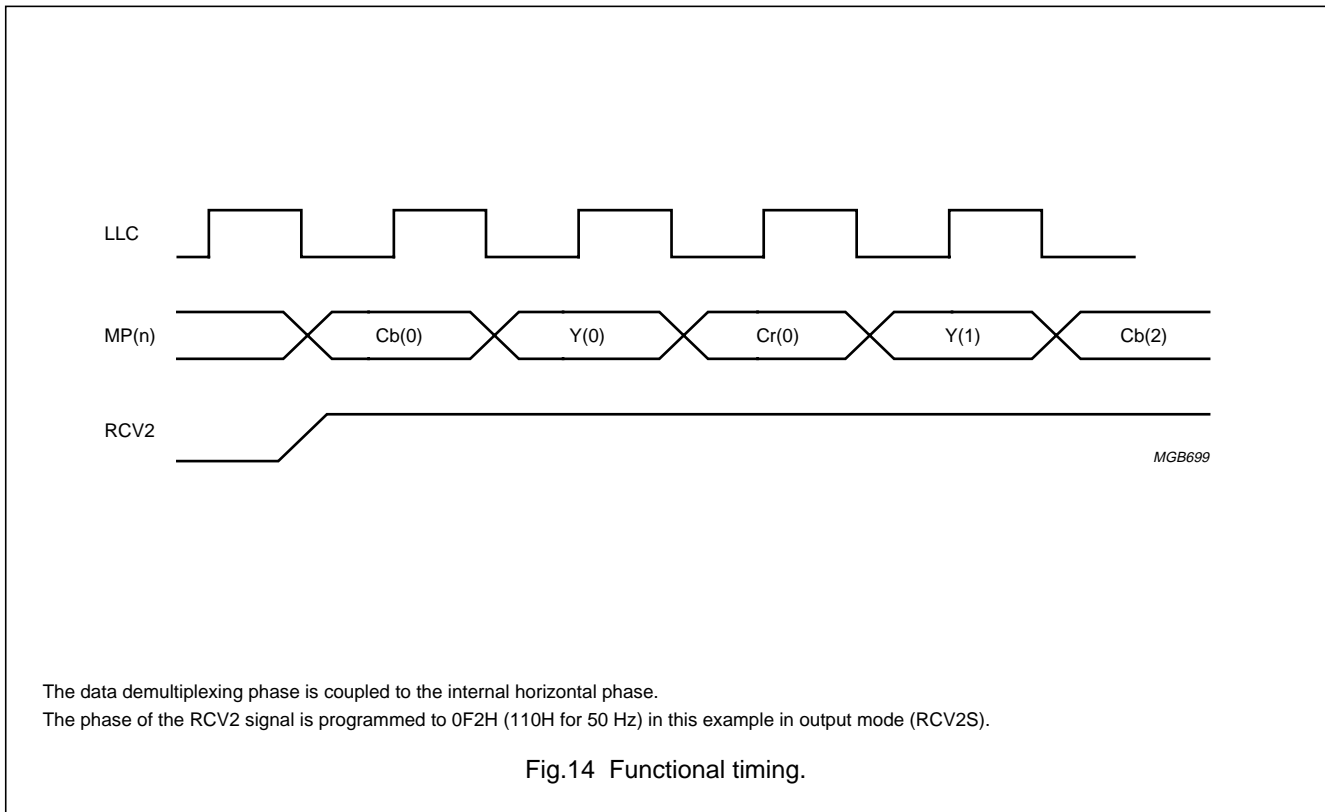
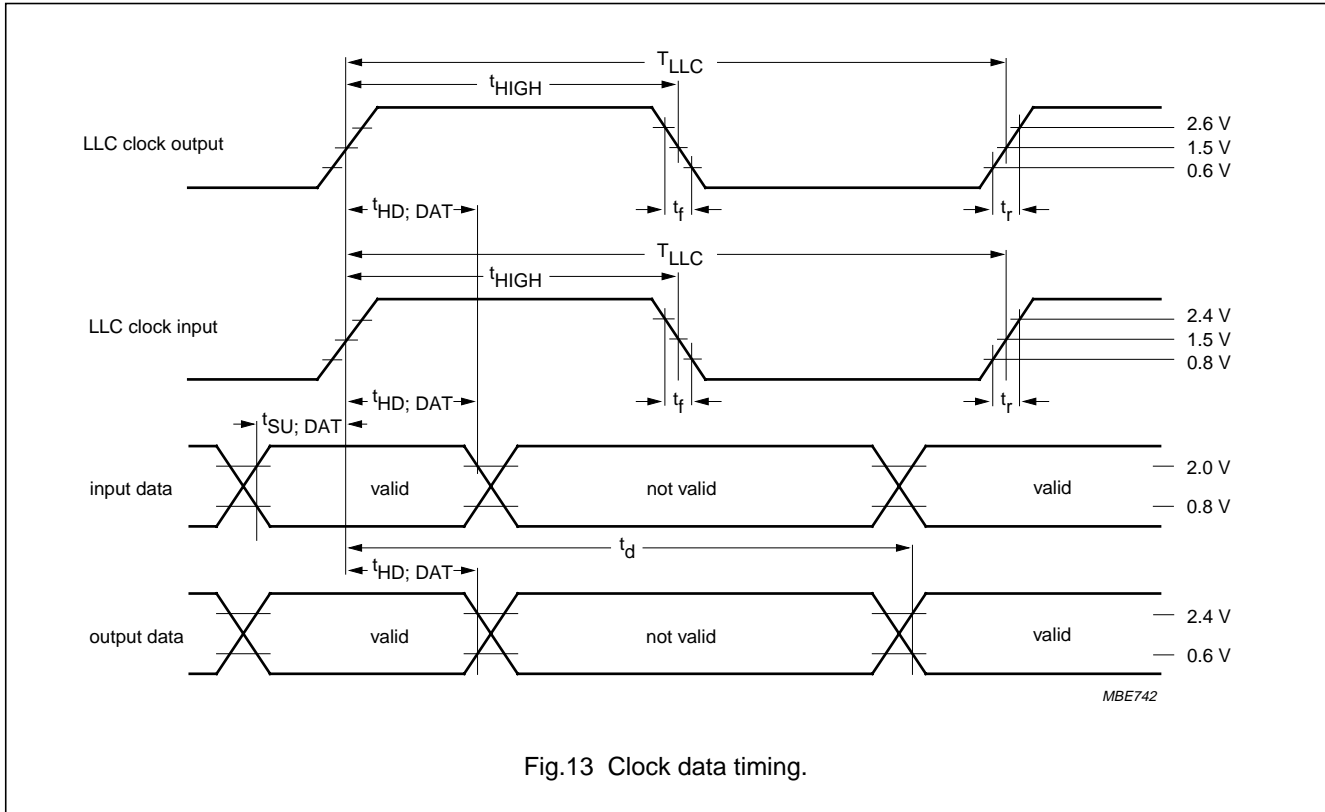



Digital Video Encoder (ECO-DENC)

SAA7124; SAA7125

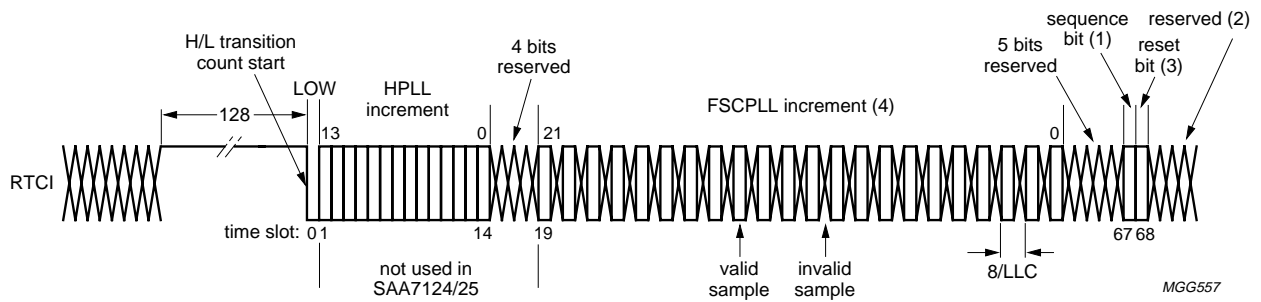

- (1) Sequence bit:  
PAL = logic 0 then (R - Y) line normal; PAL = logic 1 then (R - Y) line inverted.  
NTSC = logic 0 then no change.
- (2) Reserved bits: 235 with 50 Hz systems; 232 with 60 Hz systems.
- (3) Only from SAA7111 decoder.
- (4) SAA7111 provides (22 : 0) bits, resulting in 3 reserved bits before sequence bit.

Fig.15 RTCI timing.



Digital Video Encoder (ECO-DENC)

SAA7124; SAA7125

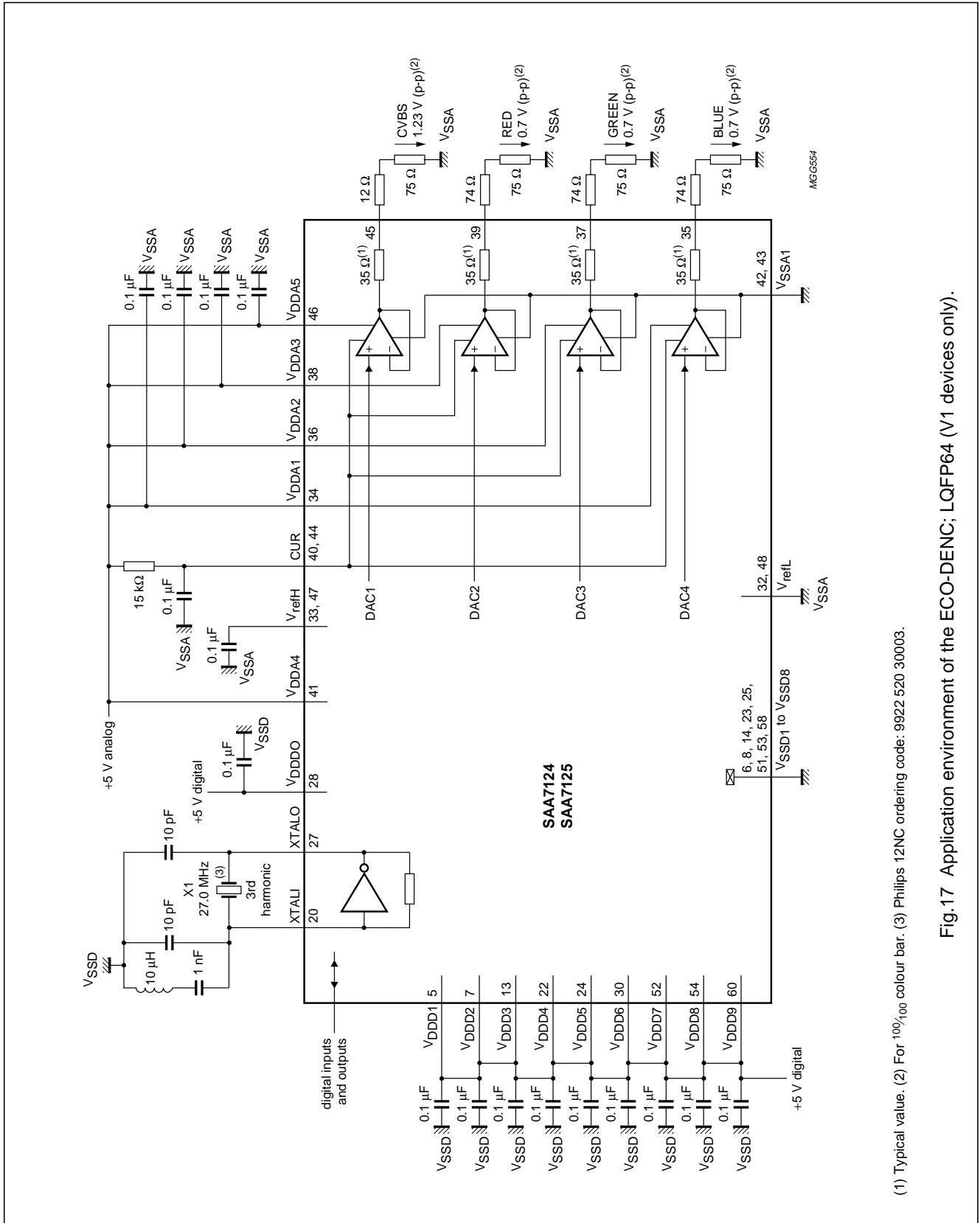

(1) Typical value. (2) For 100/100 colour bar. (3) Philips 12NC ordering code: 9922 520 30003.

Fig.17 Application environment of the ECO-DENC; LQFP64 (V1 devices only).

Digital Video Encoder (ECO-DENC)

SAA7124; SAA7125

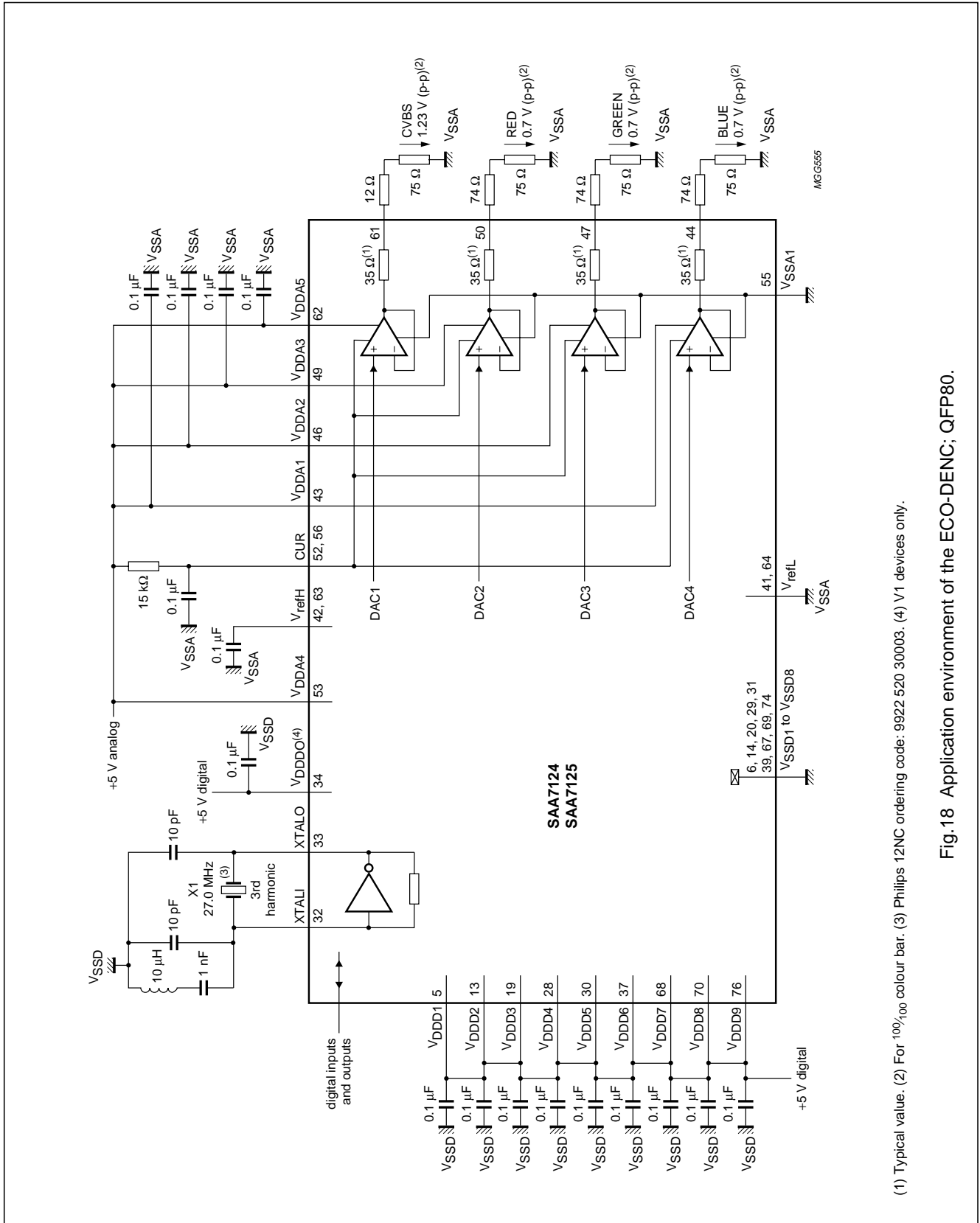

Fig.18 Application environment of the ECO-DENC; QFP80.

Digital Video Encoder (ECO-DENC)

SAA7124; SAA7125

PACKAGE OUTLINES

PLCC84: plastic leaded chip carrier; 84 leads

SOT189-2

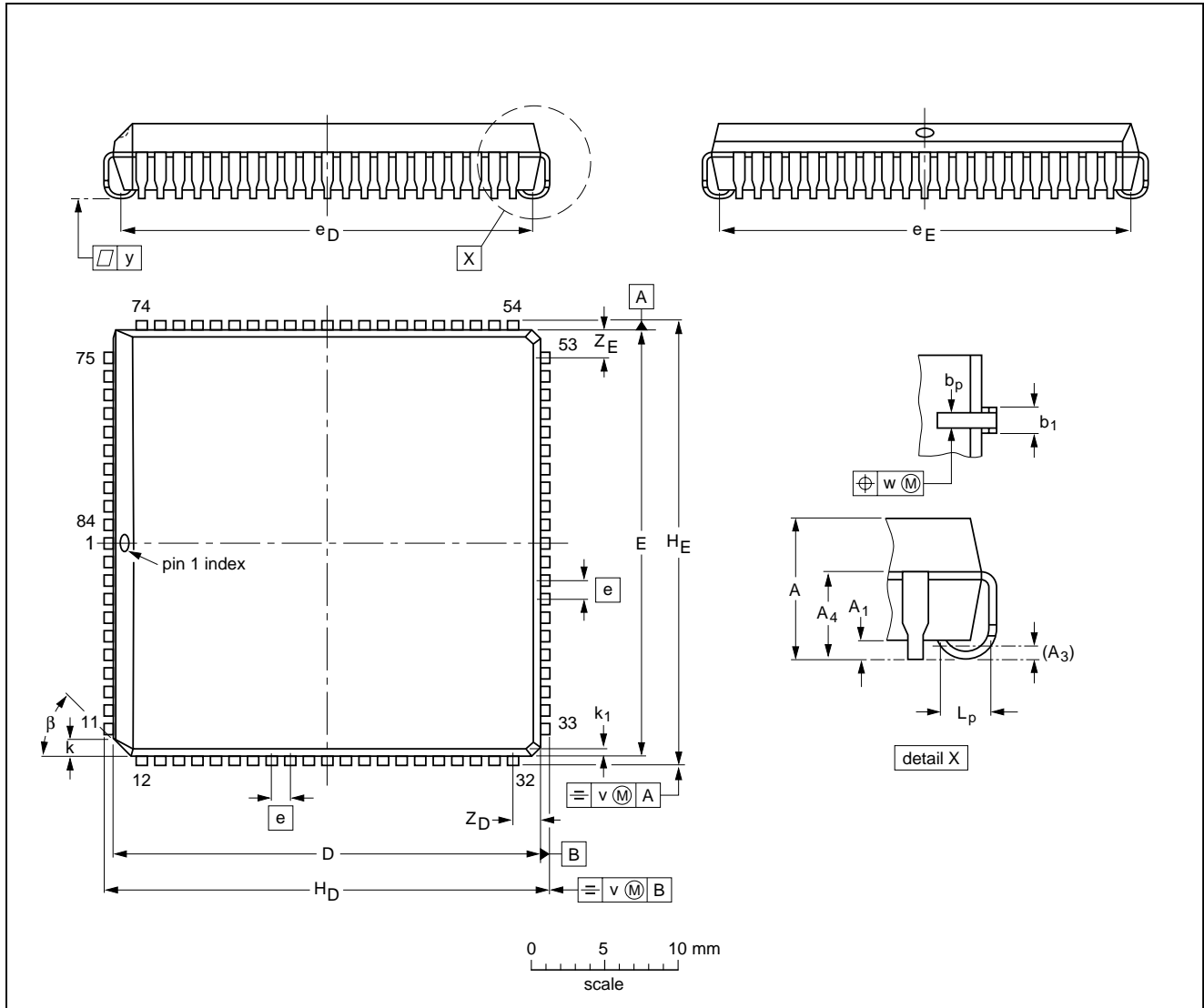

DIMENSIONS (millimetre dimensions are derived from the original inch dimensions)

UNIT	A	A <sub>1</sub> min.	A <sub>3</sub>	A <sub>4</sub> max.	b <sub>p</sub>	b <sub>1</sub>	D <sup>(1)</sup>	E <sup>(1)</sup>	e	e <sub>D</sub>	e <sub>E</sub>	H <sub>D</sub>	H <sub>E</sub>	k	k <sub>1</sub> max.	L <sub>p</sub>	v	w	y	Z <sub>D</sub> <sup>(1)</sup> max.	Z <sub>E</sub> <sup>(1)</sup> max.	$\beta$
mm	4.57 4.19	0.51	0.25	3.30 0.33	0.53 0.66	0.81 0.66	29.41 29.21	29.41 29.21	1.27	28.70 27.69	28.70 27.69	30.35 30.10	30.35 30.10	1.22 1.07	0.51	1.44 1.02	0.18	0.18	0.10	2.16	2.16	45°
inches	0.180 0.165	0.020	0.01	0.13	0.021 0.013	0.032 0.026	1.158 1.150	1.158 1.150	0.05	1.130 1.090	1.130 1.090	1.195 1.185	1.195 1.185	0.048 0.042	0.020	0.057 0.040	0.007	0.007	0.004	0.085	0.085	

Note

1. Plastic or metal protrusions of 0.01 inches maximum per side are not included.

OUTLINE VERSION	REFERENCES				EUROPEAN PROJECTION	ISSUE DATE
	IEC	JEDEC	EIAJ			
SOT189-2						92-11-17 95-03-11

Digital Video Encoder (ECO-DENC)

SAA7124; SAA7125

LQFP64: plastic low profile quad flat package; 64 leads; body 10 x 10 x 1.4 mm

SOT314-2

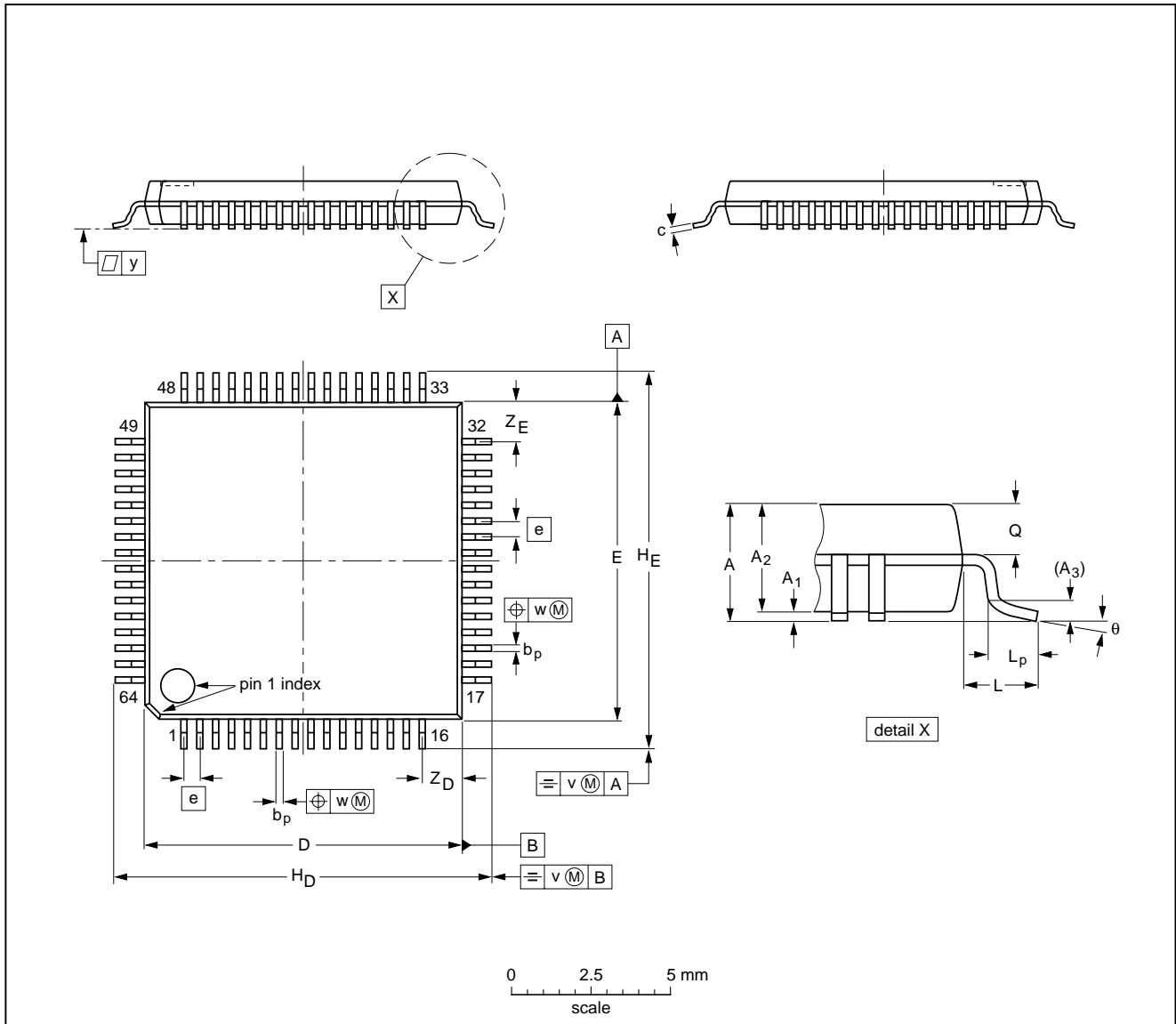

DIMENSIONS (mm are the original dimensions)

UNIT	A max.	A <sub>1</sub>	A <sub>2</sub>	A <sub>3</sub>	b <sub>p</sub>	c	D <sup>(1)</sup>	E <sup>(1)</sup>	e	H <sub>D</sub>	H <sub>E</sub>	L	L <sub>p</sub>	Q	v	w	y	Z <sub>D</sub> <sup>(1)</sup>	Z <sub>E</sub> <sup>(1)</sup>	θ
mm	1.60	0.20 0.05	1.45 1.35	0.25	0.27 0.17	0.18 0.12	10.1 9.9	10.1 9.9	0.5	12.15 11.85	12.15 11.85	1.0	0.75 0.45	0.69 0.59	0.2	0.12	0.1	1.45 1.05	1.45 1.05	7° 0°

Note

1. Plastic or metal protrusions of 0.25 mm maximum per side are not included.

OUTLINE VERSION	REFERENCES				EUROPEAN PROJECTION	ISSUE DATE
	IEC	JEDEC	EIAJ			
SOT314-2						94-01-07 95-12-19

Digital Video Encoder (ECO-DENC)

SAA7124; SAA7125

QFP80: plastic quad flat package; 80 leads (lead length 2.35 mm); body 14 x 20 x 2.8 mm

SOT318-3

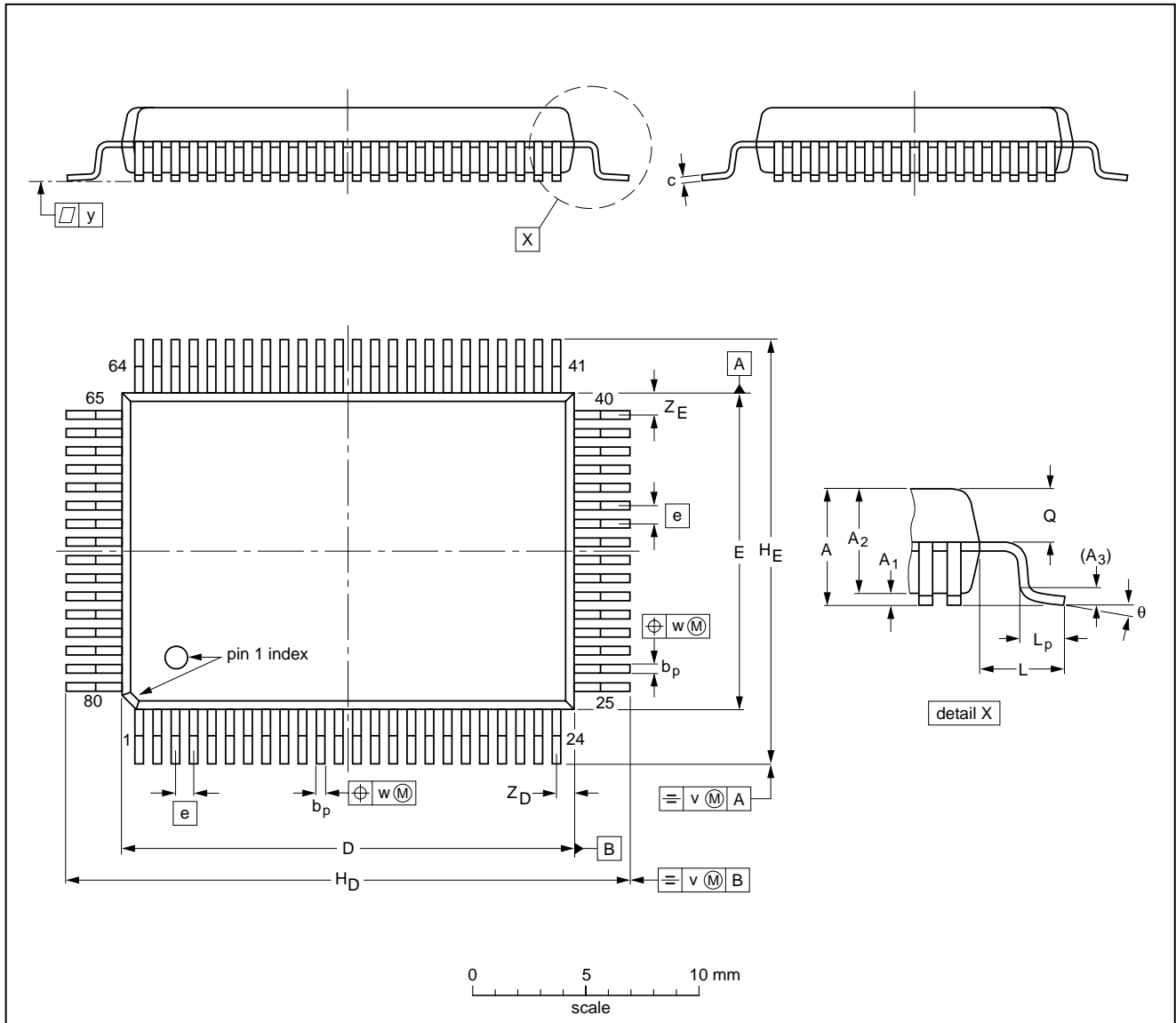

DIMENSIONS (mm are the original dimensions)

UNIT	A max.	A <sub>1</sub>	A <sub>2</sub>	A <sub>3</sub>	b <sub>p</sub>	c	D <sup>(1)</sup>	E <sup>(1)</sup>	e	H <sub>D</sub>	H <sub>E</sub>	L	L <sub>p</sub>	Q	v	w	y	Z <sub>D</sub> <sup>(1)</sup>	Z <sub>E</sub> <sup>(1)</sup>	θ
mm	3.25	0.30 0.10	2.90 2.65	0.25	0.45 0.30	0.25 0.14	20.1 19.9	14.1 13.9	0.8	25.0 24.4	19.0 18.4	2.35	1.4 1.0	1.4 1.2	0.2	0.2	0.1	1.0 0.6	1.2 0.8	7° 0°

Note

1. Plastic or metal protrusions of 0.25 mm maximum per side are not included.

OUTLINE VERSION	REFERENCES			EUROPEAN PROJECTION	ISSUE DATE
	IEC	JEDEC	EIAJ		
SOT318-3					95-02-04 95-04-25

## Digital Video Encoder (ECO-DENC)

## SAA7124; SAA7125

### SOLDERING

#### Introduction

There is no soldering method that is ideal for all IC packages. Wave soldering is often preferred when through-hole and surface mounted components are mixed on one printed-circuit board. However, wave soldering is not always suitable for surface mounted ICs, or for printed-circuits with high population densities. In these situations reflow soldering is often used.

This text gives a very brief insight to a complex technology. A more in-depth account of soldering ICs can be found in our "IC Package Databook" (order code 9398 652 90011).

#### Reflow soldering

Reflow soldering techniques are suitable for all PLCC and QFP packages.

The choice of heating method may be influenced by larger PLCC or QFP packages (44 leads, or more). If infrared or vapour phase heating is used and the large packages are not absolutely dry (less than 0.1% moisture content by weight), vaporization of the small amount of moisture in them can cause cracking of the plastic body. For more information, refer to the Drypack chapter in our "Quality Reference Handbook" (order code 9397 750 00192).

Reflow soldering requires solder paste (a suspension of fine solder particles, flux and binding agent) to be applied to the printed-circuit board by screen printing, stencilling or pressure-syringe dispensing before package placement.

Several techniques exist for reflowing; for example, thermal conduction by heated belt. Dwell times vary between 50 and 300 seconds depending on heating method. Typical reflow temperatures range from 215 to 250 °C.

Preheating is necessary to dry the paste and evaporate the binding agent. Preheating duration: 45 minutes at 45 °C.

#### Wave soldering

##### PLCC

Wave soldering techniques can be used for all PLCC packages if the following conditions are observed:

- A double-wave (a turbulent wave with high upward pressure followed by a smooth laminar wave) soldering technique should be used.

- The longitudinal axis of the package footprint must be parallel to the solder flow.
- The package footprint must incorporate solder thieves at the downstream corners.

##### QFP

Wave soldering is **not** recommended for QFP packages. This is because of the likelihood of solder bridging due to closely-spaced leads and the possibility of incomplete solder penetration in multi-lead devices.

**If wave soldering cannot be avoided, the following conditions must be observed:**

- **A double-wave (a turbulent wave with high upward pressure followed by a smooth laminar wave) soldering technique should be used.**
- **The footprint must be at an angle of 45° to the board direction and must incorporate solder thieves downstream and at the side corners.**

**Even with these conditions, do not consider wave soldering the following packages: QFP52 (SOT379-1), QFP100 (SOT317-1), QFP100 (SOT317-2), QFP100 (SOT382-1) or QFP160 (SOT322-1).**

##### METHOD (PLCC AND QFP)

During placement and before soldering, the package must be fixed with a droplet of adhesive. The adhesive can be applied by screen printing, pin transfer or syringe dispensing. The package can be soldered after the adhesive is cured.

Maximum permissible solder temperature is 260 °C, and maximum duration of package immersion in solder is 10 seconds, if cooled to less than 150 °C within 6 seconds. Typical dwell time is 4 seconds at 250 °C.

A mildly-activated flux will eliminate the need for removal of corrosive residues in most applications.

#### Repairing soldered joints

Fix the component by first soldering two diagonally-opposite end leads. Use only a low voltage soldering iron (less than 24 V) applied to the flat part of the lead. Contact time must be limited to 10 seconds at up to 300 °C. When using a dedicated tool, all other leads can be soldered in one operation within 2 to 5 seconds between 270 and 320 °C.



## Digital Video Encoder (ECO-DENC)

SAA7124; SAA7125

**DEFINITIONS**

<b>Data sheet status</b>	
Objective specification	This data sheet contains target or goal specifications for product development.
Preliminary specification	This data sheet contains preliminary data; supplementary data may be published later.
Product specification	This data sheet contains final product specifications.
<b>Limiting values</b>	
Limiting values given are in accordance with the Absolute Maximum Rating System (IEC 134). Stress above one or more of the limiting values may cause permanent damage to the device. These are stress ratings only and operation of the device at these or at any other conditions above those given in the Characteristics sections of the specification is not implied. Exposure to limiting values for extended periods may affect device reliability.	
<b>Application information</b>	
Where application information is given, it is advisory and does not form part of the specification.	

**LIFE SUPPORT APPLICATIONS**

These products are not designed for use in life support appliances, devices, or systems where malfunction of these products can reasonably be expected to result in personal injury. Philips customers using or selling these products for use in such applications do so at their own risk and agree to fully indemnify Philips for any damages resulting from such improper use or sale.

**PURCHASE OF PHILIPS I<sup>2</sup>C COMPONENTS**

Purchase of Philips I<sup>2</sup>C components conveys a license under the Philips' I<sup>2</sup>C patent to use the components in the I<sup>2</sup>C system provided the system conforms to the I<sup>2</sup>C specification defined by Philips. This specification can be ordered using the code 9398 393 40011.

Digital Video Encoder (ECO-DENC)

SAA7124; SAA7125

---

**NOTES**

Digital Video Encoder (ECO-DENC)

SAA7124; SAA7125

---

**NOTES**

# Philips Semiconductors – a worldwide company

**Argentina:** see South America

**Australia:** 34 Waterloo Road, NORTH RYDE, NSW 2113,  
Tel. +61 2 9805 4455, Fax. +61 2 9805 4466

**Austria:** Computerstr. 6, A-1101 WIEN, P.O. Box 213,  
Tel. +43 1 60 101, Fax. +43 1 60 101 1210

**Belarus:** Hotel Minsk Business Center, Bld. 3, r. 1211, Volodarski Str. 6,  
220050 MINSK, Tel. +375 172 200 733, Fax. +375 172 200 773

**Belgium:** see The Netherlands

**Brazil:** see South America

**Bulgaria:** Philips Bulgaria Ltd., Energoproject, 15th floor,  
51 James Bourchier Blvd., 1407 SOFIA,  
Tel. +359 2 689 211, Fax. +359 2 689 102

**Canada:** PHILIPS SEMICONDUCTORS/COMPONENTS,  
Tel. +1 800 234 7381

**China/Hong Kong:** 501 Hong Kong Industrial Technology Centre,  
72 Tat Chee Avenue, Kowloon Tong, HONG KONG,  
Tel. +852 2319 7888, Fax. +852 2319 7700

**Colombia:** see South America

**Czech Republic:** see Austria

**Denmark:** Prags Boulevard 80, PB 1919, DK-2300 COPENHAGEN S,  
Tel. +45 32 88 2636, Fax. +45 31 57 1949

**Finland:** Sinikalliontie 3, FIN-02630 ESPOO,  
Tel. +358 9 615800, Fax. +358 9 61580/xxx

**France:** 4 Rue du Port-aux-Vins, BP317, 92156 SURESNES Cedex,  
Tel. +33 1 40 99 6161, Fax. +33 1 40 99 6427

**Germany:** Hammerbrookstraße 69, D-20097 HAMBURG,  
Tel. +49 40 23 53 60, Fax. +49 40 23 536 300

**Greece:** No. 15, 25th March Street, GR 17778 TAVROS/ATHENS,  
Tel. +30 1 4894 339/239, Fax. +30 1 4814 240

**Hungary:** see Austria

**India:** Philips INDIA Ltd, Shivsagar Estate, A Block, Dr. Annie Besant Rd.  
Worli, MUMBAI 400 018, Tel. +91 22 4938 541, Fax. +91 22 4938 722

**Indonesia:** see Singapore

**Ireland:** Newstead, Clonskeagh, DUBLIN 14,  
Tel. +353 1 7640 000, Fax. +353 1 7640 200

**Israel:** RAPAC Electronics, 7 Kehilat Saloniki St, TEL AVIV 61180,  
Tel. +972 3 645 0444, Fax. +972 3 649 1007

**Italy:** PHILIPS SEMICONDUCTORS, Piazza IV Novembre 3,  
20124 MILANO, Tel. +39 2 6752 2531, Fax. +39 2 6752 2557

**Japan:** Philips Bldg 13-37, Kohnan 2-chome, Minato-ku, TOKYO 108,  
Tel. +81 3 3740 5130, Fax. +81 3 3740 5077

**Korea:** Philips House, 260-199 Itaewon-dong, Yongsan-ku, SEOUL,  
Tel. +82 2 709 1412, Fax. +82 2 709 1415

**Malaysia:** No. 76 Jalan Universiti, 46200 PETALING JAYA, SELANGOR,  
Tel. +60 3 750 5214, Fax. +60 3 757 4880

**Mexico:** 5900 Gateway East, Suite 200, EL PASO, TEXAS 79905,  
Tel. +9-5 800 234 7381

**Middle East:** see Italy

**Netherlands:** Postbus 90050, 5600 PB EINDHOVEN, Bldg. VB,  
Tel. +31 40 27 82785, Fax. +31 40 27 88399

**New Zealand:** 2 Wagener Place, C.P.O. Box 1041, AUCKLAND,  
Tel. +64 9 849 4160, Fax. +64 9 849 7811

**Norway:** Box 1, Manglerud 0612, OSLO,  
Tel. +47 22 74 8000, Fax. +47 22 74 8341

**Philippines:** Philips Semiconductors Philippines Inc.,  
106 Valero St. Salcedo Village, P.O. Box 2108 MCC, MAKATI,  
Metro MANILA, Tel. +63 2 816 6380, Fax. +63 2 817 3474

**Poland:** Ul. Lukiska 10, PL 04-123 WARSZAWA,  
Tel. +48 22 612 2831, Fax. +48 22 612 2327

**Portugal:** see Spain

**Romania:** see Italy

**Russia:** Philips Russia, Ul. Usatcheva 35A, 119048 MOSCOW,  
Tel. +7 095 247 9145, Fax. +7 095 247 9144

**Singapore:** Lorong 1, Toa Payoh, SINGAPORE 1231,  
Tel. +65 350 2538, Fax. +65 251 6500

**Slovakia:** see Austria

**Slovenia:** see Italy

**South Africa:** S.A. PHILIPS Pty Ltd., 195-215 Main Road Martindale,  
2092 JOHANNESBURG, P.O. Box 7430 Johannesburg 2000,  
Tel. +27 11 470 5911, Fax. +27 11 470 5494

**South America:** Rua do Rocio 220, 5th floor, Suite 51,  
04552-903 São Paulo, SÃO PAULO - SP, Brazil,  
Tel. +55 11 821 2333, Fax. +55 11 829 1849

**Spain:** Balmes 22, 08007 BARCELONA,  
Tel. +34 3 301 6312, Fax. +34 3 301 4107

**Sweden:** Kottbygatan 7, Akalla, S-16485 STOCKHOLM,  
Tel. +46 8 632 2000, Fax. +46 8 632 2745

**Switzerland:** Allmendstrasse 140, CH-8027 ZÜRICH,  
Tel. +41 1 488 2686, Fax. +41 1 481 7730

**Taiwan:** PHILIPS TAIWAN Ltd., 23-30F, 66,  
Chung Hsiao West Road, Sec. 1, P.O. Box 22978,  
TAIPEI 100, Tel. +886 2 382 4443, Fax. +886 2 382 4444

**Thailand:** PHILIPS ELECTRONICS (THAILAND) Ltd.,  
209/2 Sanpavuth-Bangna Road Prakanong, BANGKOK 10260,  
Tel. +66 2 745 4090, Fax. +66 2 398 0793

**Turkey:** Talatpasa Cad. No. 5, 80640 GÜLTEPE/ISTANBUL,  
Tel. +90 212 279 2770, Fax. +90 212 282 6707

**Ukraine:** PHILIPS UKRAINE, 4 Patrice Lumumba str., Building B, Floor 7,  
252042 KIEV, Tel. +380 44 264 2776, Fax. +380 44 268 0461

**United Kingdom:** Philips Semiconductors Ltd., 276 Bath Road, Hayes,  
MIDDLESEX UB3 5BX, Tel. +44 181 730 5000, Fax. +44 181 754 8421

**United States:** 811 East Arques Avenue, SUNNYVALE, CA 94088-3409,  
Tel. +1 800 234 7381

**Uruguay:** see South America

**Vietnam:** see Singapore

**Yugoslavia:** PHILIPS, Trg N. Pasica 5/v, 11000 BEOGRAD,  
Tel. +381 11 625 344, Fax. +381 11 635 777

**For all other countries apply to:** Philips Semiconductors, Marketing & Sales Communications,  
Building BE-p, P.O. Box 218, 5600 MD EINDHOVEN, The Netherlands, Fax. +31 40 27 24825

**Internet:** <http://www.semiconductors.philips.com>

© Philips Electronics N.V. 1996

SCA52

All rights are reserved. Reproduction in whole or in part is prohibited without the prior written consent of the copyright owner.

The information presented in this document does not form part of any quotation or contract, is believed to be accurate and reliable and may be changed without notice. No liability will be accepted by the publisher for any consequence of its use. Publication thereof does not convey nor imply any license under patent- or other industrial or intellectual property rights.

Printed in The Netherlands

657021/1200/01/pp44

Date of release: 1996 Nov 07

Document order number: 9397 750 01467

*Let's make things better.*

**Philips**  
Semiconductors



**PHILIPS**